

K1, K2, K8 PRESSURE TRANSDUCER INSTRUCTION SHEET



⚠ WARNING! READ ⚠ BEFORE INSTALLATION

1. GENERAL:

A failure resulting in injury or damage may be caused by excessive overpressure, excessive vibration or pressure pulsation, excessive instrument temperature, corrosion of the pressure containing parts, or other misuse. Consult Ashcroft Inc., Stratford, Connecticut, USA before installing if there are any questions or concerns.

2. OVERPRESSURE:

Pressure spikes in excess of the rated overpressure capability of the transducer may cause irreversible electrical and/or mechanical damage to the pressure measuring and containing elements.

Fluid hammer and surges can destroy any pressure transducer and must always be avoided. A pressure snubber should be installed to eliminate the damaging hammer effects. Fluid hammer occurs when a liquid flow is suddenly stopped, as with quick closing solenoid valves. Surges occur when flow is suddenly begun, as when a pump is turned on at full power or a valve is quickly opened.

Liquid surges are particularly damaging to pressure transducers if the pipe is originally empty. To avoid damaging surges, fluid lines should remain full (if possible), pumps should be brought up to power slowly, and valves opened slowly. To avoid damage from both fluid hammer and surges, a surge chamber should be installed.

Symptoms of fluid hammer and surge's damaging effects:

- Pressure transducer exhibits an output at zero pressure (large zero offset).
- Pressure transducer output remains constant regardless of pressure
- In severe cases, there will be no output.

FREEZING:

Prohibit freezing of media in pressure port. Unit should be drained (mount in vertical position with electrical termination upward) to prevent possible overpressure damage from frozen media.

3. STATIC ELECTRICAL CHARGES:

Any electrical device may be susceptible to damage when exposed to static electrical charges. To avoid damage to the transducer observe the following:

- Operator/installer should follow proper ESD (electrostatic discharge) protection procedures before handling the pressure transducer.

Note: The shield and drain wire in the cable (if supplied) is not connected to the transducer body, and is not a suitable ground.

MOUNTING

The transducer requires no special mounting hardware, and can be mounted in any plane with negligible position error.

Although the unit can withstand normal vibration without damage or significant output effects, it is always good practice to mount the transducer where there is minimum vibration.

For units with NPT type pressure fittings apply teflon tape or an equivalent sealant to the threads before installing.

When tightening, apply a wrench to the hex wrench flats located just above the pressure fitting. **DO NOT** tighten by using a pipe wrench on the housing.

POWER SUPPLY – K1 Models Only

The supply voltage for the 1-5 and 1-6 Vdc output transducers must be within the range of 10 to 36 Vdc. The maximum supply voltage for a 4-20mA current output transducer is 36 Vdc while the minimum supply voltage is dependent upon the loop resistance of the circuit. The load limitation chart shows the minimum supply voltage (V_{min}) required for a given loop resistance (R_{LOOP}).

NOISE

For minimum noise susceptibility, avoid running the transducer's cable in a conduit that contains high current AC power cables. Where possible avoid running the cable near inductive equipment.

SHIELD WIRING

Connect the braided shield to the guard terminal on the reading instrument (meter, etc.) if available or to ground or to the power supply negative terminal.

ADJUSTMENT POTENTIOMETERS

The zero and span pots are accessible through the top of the case. Loosen the four screws and separate the top carefully. The zero pot is marked with a white dot.

VENT TUBE

The cable will have a clear Teflon vent tube that's required at pressure below 500 psi to provide atmospheric reference. The open end should be placed in a dry area.

OUTPUT – K8 Only

Sensitivity may be from 6 mV/V to 18 mV/V for any individual transducer. Zero offset is within ± 3 mV/V. Output is proportional to supply voltage (ratiometric).

EXCITATION – K8 & K2

For proper operation a voltage within the range of 5 to 10 Vdc must be applied between the transducer's supply terminals.

Load Limitations 4-20mA Output Only

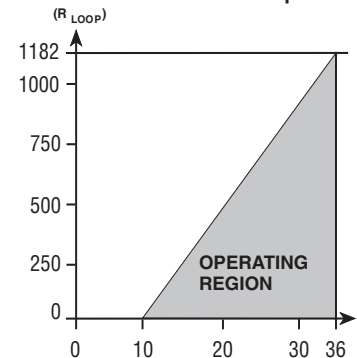

$$V_{min} = 10V + (.022A \times R_L)$$

$$R_L = R_S + R_W$$

R_L = Loop Resistance (ohms)

R_S = Sense Resistance (ohms)

R_W = Wire Resistance (ohms)

K1, K2, K8 PRESSURE TRANSDUCER INSTRUCTION SHEET



Wiring Diagrams for All Transducers

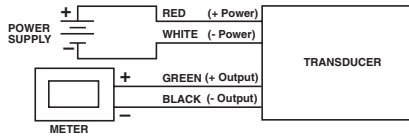

4-Wire Ratiometric (mV/V)

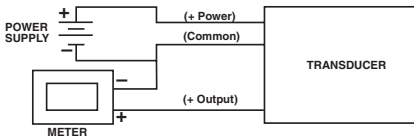



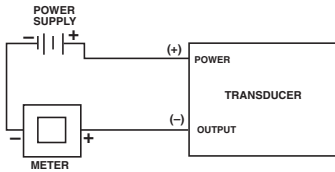

3-Wire Voltage





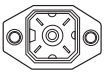

4-20 mA

K1 Transducers – Electrical Connections

Voltage Output Units 1-5, 1-6 Vdc

CONNECTOR TYPE	MATING CONNECTOR CABLE CODING
 Hirschmann Type PIN 1 = + Power PIN 2 = Common PIN 4 = Output	Red Black Green
 Bendix 4-Pin, 6-Pin Pin A = + Power Pin B = Output Pin D = Common	Red Green White
 Cable Type F2 Red = + Power White = Common Green = Output	N/A
 Cable Type C1 Red = + Power White = Common Green = Output	N/A

Current Output Units 4-20mA

CONNECTOR TYPE	MATING CONNECTOR CABLE CODING
 Cable Type F2 Red = + Power Black = - Power	N/A
 Cable Type C1 Red = + Power Black = - Power	N/A
 Hirschmann Type Pin-1 = + Power Pin-2 = - Power	Red Black
 Bendix 4-Pin, 6-Pin Pin A = + Power Pin B = - Power	Red Green

Dimensions

NOTE: All dimensions are decimal inches

K1, K2 Transducers

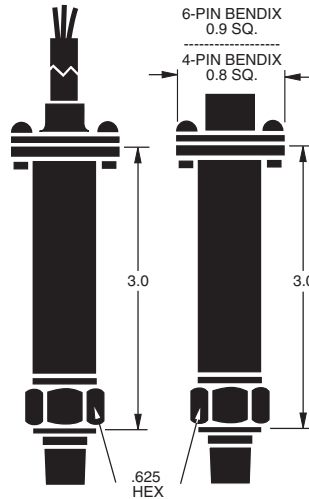



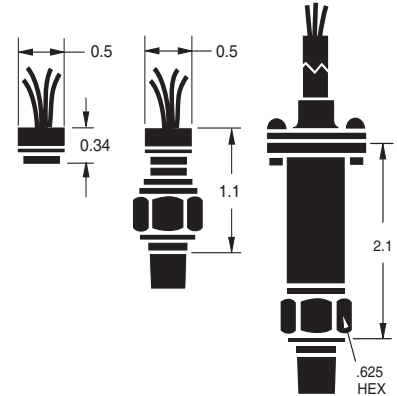

K8 Transducers





K2 Transducers – Electrical Connections

Ratiometric (mV/V)

CONNECTOR TYPE	MATING CONNECTOR CABLE CODING
 Cable Type F2 Red = + Power White = - Power Green = + Output Black = - Output	N/A
 Cable Type C1 Red = + Power White = - Power Green = + Output Black = - Output	N/A
 Bendix 4-Pin Pin A = +Power Pin B = +Output Pin C = -Output Pin D = -Power	Red Green Black White
 Bendix 6-Pin Pin A = +Power Pin D = -Power Pin B = +Output Pin C = -Output Pin E = Shunt Cal. Pin F = Shunt Cal.	Red White Green Black

K8 Transducers – Electrical Connections

Ratiometric (mV/V)

 Cable Type F2 Red = + Power White = - Power Green = + Output Black = - Output
 4 Inch Leads Red* = + Power White = - Power Green = + Output Blue = - Output *Orange = + Power, RoHS compliant versions

Special Wiring – See "X" Variation On Unit Label

Variation	Wire Hookup
XTQ	Red = + Power Black = Common White = Output
XTG	Red = + Power Black = Common Green = Output

Recalibration Instructions:

1. Apply 0% Full Scale Pressure.
2. Set the output using the *Zero adjustment potentiometer*.
3. Apply 100% Full Scale Pressure.
4. Set the output using the *Span adjustment potentiometer*.
5. Repeat steps 1 thru 4 as necessary.