



**Quick Start Function Summary
Instructions for ASHCROFT®
GC52 Differential Pressure
Transmitter
Version 6.03 Rev. B**

(See Complete I&M Manual for Further Detail)



LOOK FOR THIS
AGENCY MARK ON
OUR PRODUCTS

DISPLAY OVERVIEW

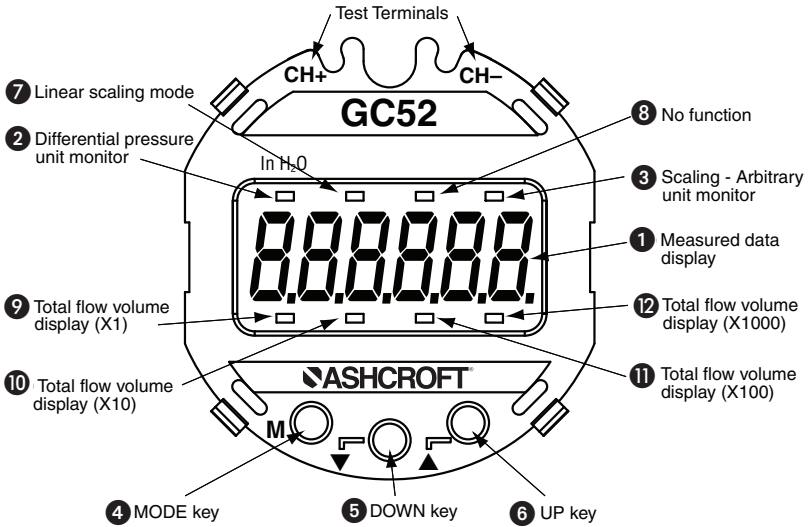

DESIGNATION	FUNCTION
1 Measured data display	Differential pressure, linear scaling value are displayed.
2 Differential pressure unit monitor	When this unit monitor is ON, the differential pressure (in H ₂ O) is indicated on the measured data display.
3 Scaling; arbitrary unit monitor	When this unit monitor is ON, the scaling value of an arbitrary unit (linear scaling), is indicated on the measured data display.
4 MODE key (M)	This key is used to switch the setting mode and the measurement mode and to change the setting item.
5 DOWN key (▼)	This key is used to change (decrease) and select the set value.
6 UP key (▲)	This key is used to change (increase) and select the set value and to shift from the measurement mode to the zero adjustment mode.
7 Linear scaling mode	Change differential pressures into quantity
8 No function	None
9 to 12 Total flow volume display	Accumulated volume calculated based on flow rate

1. **UPON POWER-UP** the unit enters “Measure Mode” – displaying applied pressure.
2. **TWO FUNCTION** is available to the user in “Measure Mode”.

- A. **Zero Adjustment Mode:** In the measurement mode, the pressure connection is open to the atmosphere and \blacktriangle key is pressed for more than 3 seconds in order to shift to zero adjustment mode for zero point adjustment of the differential pressure sensor
 - If the zero point adjustment is performed correctly the message “ADJ” will be displayed for 2 seconds, and the display will return to the measurement mode.
- B. **Key Lock**

Function	Key Manual	Indicator
Setting of key lock	MODE+ \blacktriangle one second	LoC (Key invalidity)
Release of key lock	MODE+ \blacktriangle one second	UnL (Key invalidity)
Operation during keylock		
Function	Key Manual	Indicator
Zero adjust. mode	\blacktriangle key greater than 3 sec	LoC (Key invalidity)
Hold value reset	\blacktriangledown key greater than 3 sec	LoC (Key invalidity)

3. **FIVE FUNCTIONS** available to the User via “Setting Mode”. To enter the “Setting Mode” hold (M) key for more than 3 seconds. (See last page for complete Setting Mode menu.)

- A. **Filter (Damping)**

The filter is based on the moving average of the pressure data to decrease display “bounce” and to smooth the analog output due to system pressure fluctuations at the user’s discretion.

Five selections: (0, 2, 4, 8 and 16 seconds), Use \blacktriangle \blacktriangledown keys to change value.

If “0” is selected the filter is not applied.

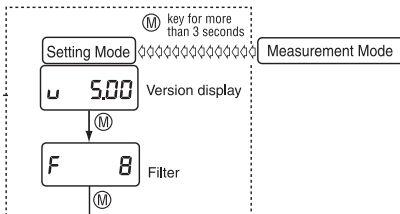

- B. **Re-scaling in “inH₂O” units:** “Pressure Display Mode” allows for zero (4mA) and span (20ma) adjustment of –10 to +110% Span respectively.

Note: 1. See menu schematic on last page for detail.

2. Must be in “Pressure Display Mode” option within “Setting Mode,” this is noted on the screen by

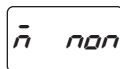

Use \blacktriangle \blacktriangledown keys to move between “Pressure Display Mode” and “Linear Display Mode” which is for re-scaling in “Arbitrary” units.

3. To adjust Output Zero Point (4mA) and Output Span Point (20mA) the unit must be in the functional area as noted below while adjustment is via \blacktriangle \blacktriangledown keys. The value shown is a percentage of the pressure range (span) as noted on the product label (ex. If product was supplied as a 0-40 IWC range and the user desired the Output Zero Point (4mA) to be “moved” from 0 IWC to 20 IWC then Output Zero Point would be 50.0 which is 50%.

Values shown below are from I&M manual.

Setting Item	LCD Display	Setting Description	Setting Range
Display mode		Selection of pressure display mode : non	non:pressure display mode Lin: linear display mode
Output zero point		Analog output zero point (4mA) : 10.0 (%Span)	Pressure range:-10 to 110% Span
Output span point		Analog output span point (20mA) : 90.0 (%Span)	Pressure range:-10 to 110% Span

Note: For setting of zero point and span point in the analog output, input the percent value over the pressure range.

- C. **Re-scaling in “Arbitrary” units, “Linear Display Mode.”** This function allows the user to establish a linear relationship from the standard “inH₂O” unit to any user defined unit.

Note: See menu schematic on last page. Unit must be in “Linear Display Mode” option within “Setting Mode”, this is noted on the screen by

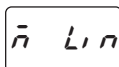

Use \blacktriangle \blacktriangledown keys to move between “Linear Display Mode” and “Pressure Display Mode.”

Setting Item	LCD Display	Setting Description	Setting Range
Display mode		Selection of linear display mode: Lin	non: Differential pressure display mode; Lin: Linear display mode
Min. differential pressure		Min. differential pressure corresponding to OFFSET (Ⓔ):20.0(inH ₂ O)	Differential pressure range: 0 to 75% Span
Max. differential pressure		Max. differential pressure corresponding to FULL SCALE (Ⓔ):120(inH ₂ O)	Differential pressure range: 25 to 100%Span
Decimal point position		Display after decimal point Number of digits: 1 (digit)	0,1,2,3 digit
OFFSET		OFFSET corresponding min. differential pressure (Ⓔ): 0.0 (m)	-1999 to 1999
FULL SCALE		FULL SCALE corresponding to max. differential pressure (Ⓔ):50.0 (m)	-1999 to 1999
Output zero point		Analog output zero point : (4mA): 0.0 (%Span)	Max. display span: -10 to 110% Span
Output span point		Analog output span point : (20mA): 100.0 (%Span)	Max. display span: -10 to 110%Span

Note: Values shown are from example in I&M manual.

D. Flow Measurement/Square Root Extraction Mode Mode Square Square Root Display Mode

Combining the sensing elements (orifice and pitot tube) with this product, the mode is used for the display of the momentary flow rate, integrated volume and for analog output corresponding to the momentary flow rate.

(1) Momentary flow rate

The momentary flow rate display has the maximum display span from zero to the maximum momentary flow rate. The **Momentary flow rate display span** depends on the setting of the zero point and span point of the analog output as shown in (2) analog output. It can display 0 to 105%F.S. display span. The scaling method of momentary flow rate can be performed only by setting the maximum momentary flow rate and then generate differential pressure using the following square root formula.

Momentary flow rate D_x is expressed by the square root formula (a), and can be calculated only by measuring the generated differential pressure P_x (percent value over the differential pressure range).

$$(a) \quad D_x = k \times \sqrt{\frac{P_x(\%)}{100(\%)}}$$

In addition, the coefficient k is determined by substituting the maximum momentary flow rate D_m , which is measured from the formula (a), and the then generated differential pressure P_m into the formula (b).

$$(b) \quad k = \sqrt{\frac{D_m}{P_m \cdot 100}}$$

- The **differential pressure generated** during the maximum momentary flow rate can be set in the range of 25 to 100%F.S. of the differential pressure range.
- The setting range for values of the **maximum momentary flow rate** is 0 to 1999. Note: The decimal point can be set arbitrarily.
- When the display resolution lowers and the wobbling of momentary flow rate increases in the low flow domain of the differential pressure flow meter, the domain (below the set value) will be forcedly indicated as zero by means of the **low-cut for momentary flow rate**.

Moreover, the analog output has a fixed value of 4mA at the zero point. For setting of low-cut, input the percent value over the maximum display span. Its range is 0 to 30%F.S. and the decimal point position can be set up to one digit after decimal point as fixed point.

(2) Analog output

The zero point (4mA) and span point (20mA) of analog output can be set in the range of 0 to 110%F.S. of the maximum display span (0 to maximum momentary flow rate). The span between the zero point and the span point in this analog output is the momentary flow rate display span.

(3) Integrated volume

- The **units of integrated volume** include two standards: Time factor and flow rate volume factor.
- The **number of digits of integrated volume display** is a maximum of 6 figures (999999); the display will return to 0 once the maximum reading has been met.



- The zero reset of an integrated volume is executed by pressing  key for more than 3 seconds and displaying "cLr" (clear) for 2 seconds.



- As **backup in case of POWER OFF**, the integrated volume value is stored in the nonvolatile memory for every hour. After power returns, integration starts from the integrated volume value stored in the memory.
- Integration is halted during the "FFF" display **at the time of differential pressure range OVER**.

- The indicated value which is blinking is integrated during the "blink" display at the time of momentary flow rate display span OVER.

Flow Measurement/Square Root Extraction Mode

No.	Setting Item	LCD Display	Setting Description	Setting Range	Default
②	Display mode	\bar{n} rot	Selection for flow measurement/ square root extraction mode	non : Differential pressure display mode Lin : Linear display mode Rot : Square root display mode	non
⑭	Maximum differential selection ¹	P. 400	Maximum differential pressure relating to the flow rate	25 to 100% F.S. of sensor range	100.0% of sensor range
⑮	Flow rate decimal pt. position	d 0	Displays of value after decimal point, # of digits	0,1,2,3 digit	0
⑯	Max. momentary flow	d 1000	Max. momentary of flow using arbitrary units	0 to 1999	1000
⑰	Low cut	L 00	Forces display and output to zero	0.0 to 30.0% F.S. of max. display span	0.0
⑱	Output zero point ²	R 00	Momentary flow rate of analog output zero point (4mA): 100.0% F.S.	-10 to 100% F.S. of max. display span	0.0
⑲	Output span point ²	R 1000	Momentary flow rate of analog output zero point (20mA): 100.0% F.S.	-10 to 100% F.S. of max. display span	100.0
⑳	Time factor	U SEC	Measurement of max. momentary flow rate over time selected	Seconds, minutes or hours	Sec
㉑	Flow rate volume factor	U 1	Flow rate x time selected	1,10,100,1000	1
㉒	Display switch setting	S bt	Selection of display switching method of momentary flow rate and integrated volume	ti = automatic bt = manual	bt
㉓	Switch time interval	t 5	Selection for ti: automatic Displays switching time interval in seconds	1 to 10 seconds (10 stage)	5
㉔	Loop check ³	c 00	Output check using arbitrary value – displays pressure correlating to the 4 to 20mA signal	Display: momentary flow rate display span Analog output: 4 to 20mA 0.0 to 100.0%	0 (4.0mA)

- (1) In the setting of a differential pressure the decimal point position is fixed for each differential pressure range. The max. differential pressure can be set from the value which is 25%F.S of the differential pressure range above the minimum differential pressure. The values under 25%F.S. cannot be increased or decreased by Δ , ∇ key.
- (2) For setting zero point and span point of the analog output, input the percent value over the maximum display span (between OFFSET and FULL SCALE). Its decimal point position can be set up to one digit after the decimal point (xx.x).
- (3) Regardless of generated differential pressure or low-cut, the loop check can be changed arbitrarily linking the momentary flow rate display with the analog output using the Δ , ∇ keys. This example of LCD display shows the display set to span point.

(4) Display switching method of momentary flow rate and integrated volume

Display switching methods of momentary flow rate and integrated volume include the **automatic switching display method** to display them by turns at intervals of fixed time (1 to 10 seconds) and the manual switching display method to change the display by pressing **(M)** key.

Complete Setting Mode Menu

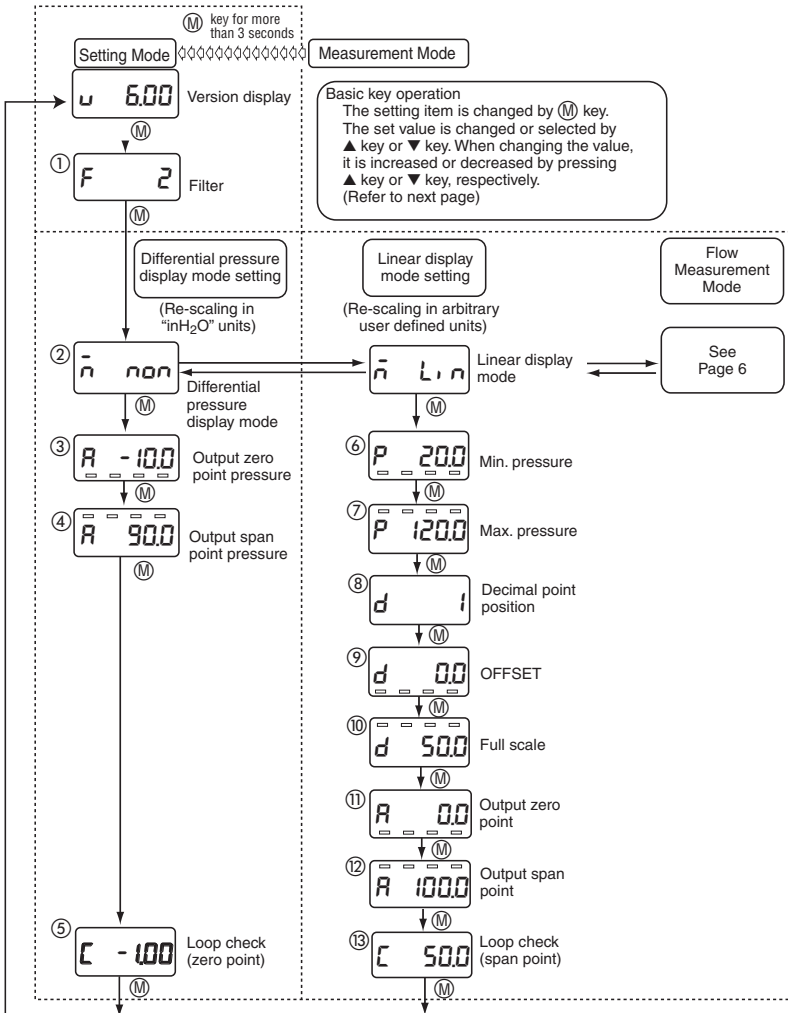

E. Loop Check: Use to send a 4-20mA signal meant to simulate applied pressure, can be accessed either through Pressure Display Mode or Linear Display Mode. See “Complete Setting Mode Menu”; Loop Check is noted on the screen with a prefix “L”. The display is indicating in actual units and starts at the zero (4mA) point.

If **▲** button is pressed, the linear display will auto increment by linkage between the linear display and the analog output. By continuing to press **▼** button, auto decrement will occur. Release the button at the desired indication.

Flow Measurement Mode (Square Root Extraction) Setting

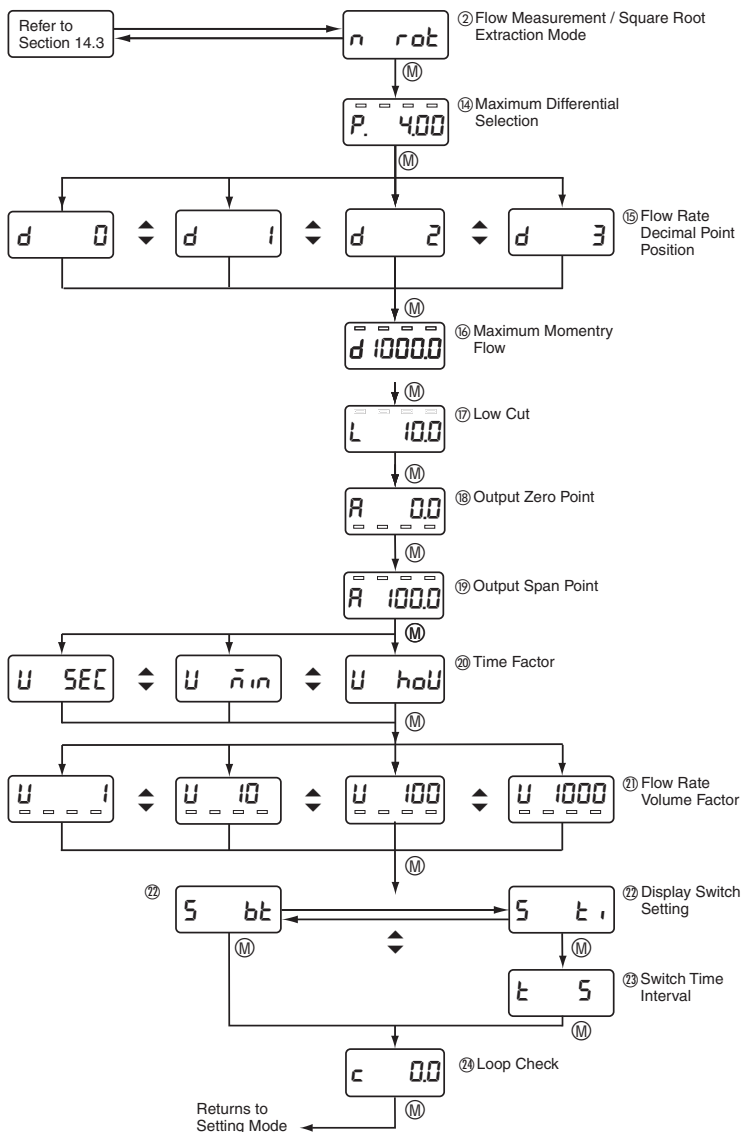

4. WIRING

Power supply requirements, 12-36Vdc, note installation recommendations as follows:

Terminal Strip: SMKDSP1.5/2-5.08 Phoenix contact

A. Cable Requirements

- Two core shielded cable
- Cable outer diameter: 0.35" to 0.47" (9-12mm)
Required for proper installation with cable gland option
- Wire Gauge: 14-22 AWG (multi-strand or solid)

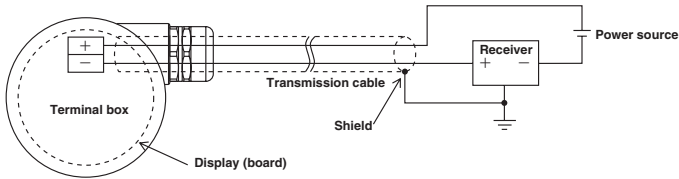

B. Wiring Instructions

- Do not run pressure transmitter cable / wires within the same conduit as high voltage (line power) line to reduce the potential for noise (interference).
Use dedicated conduit on GC52 cables / wires for optimum results.
- Cable diameter, specified above, must be maintained when using the Cable Gland termination to retain environmental ratings.
- When connecting shield / drain wire, only connect one end which should be at the received ground.
- Wire stripping instructions; remove cable jacket 2-3" and strip wires 0.25".
Shield / drain wire should not be exposed at the pressure transmitter termination.

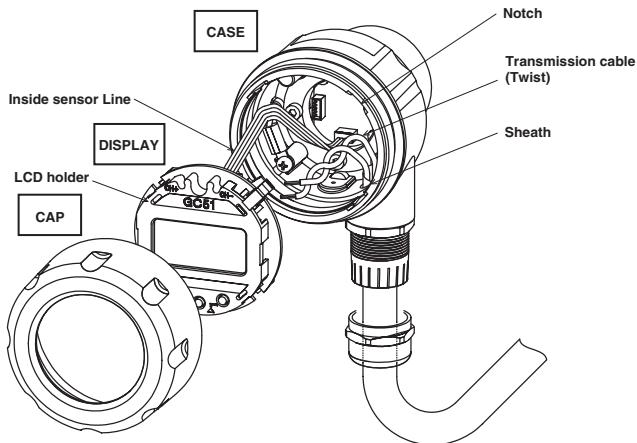

- Remove cover and carefully remove the display to access the terminal strip, take care not to mishandle the display and associated electronics.
- Turn display over to expose terminal strip, make positive and negative connections; insert wire equal to the recommended strip length (0.25").
- After completing connections, align the retaining clips of the display with the housing's notches and carefully place into the housing. Be sure that the internal sensor ribbon cable does not cross the power supply lines just installed.
- Be sure to properly tighten the sealing grommet when using the Cable Gland before applying tension to the cable; the cable gland provides strain relief and environmental sealing.
- Tighten GC52 cover to maintain environmental rating.
- Connect to power source and receiver, then apply power to confirm correct wiring.

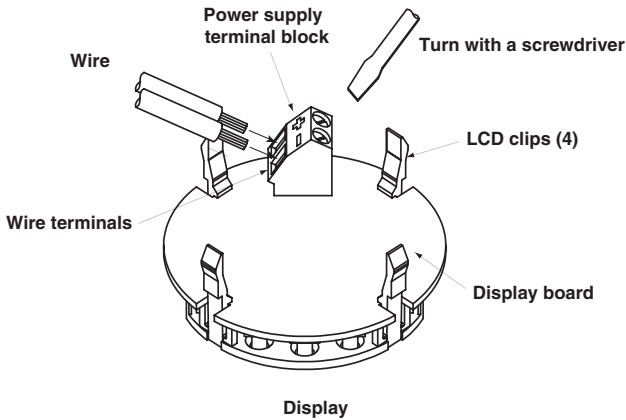

- Power Supply Requirements: Although the 4-20mA signal can travel over long distances, a very common issue to arise involves inadequate power at the pressure transmitter – this results in voltage drop across the loop. Be sure to review the accompanying table to determine whether the 12-36Vdc has been received at the pressure transmitter.

Load Limitations 4-20mA Output Only

Loop Resistance (Ω)

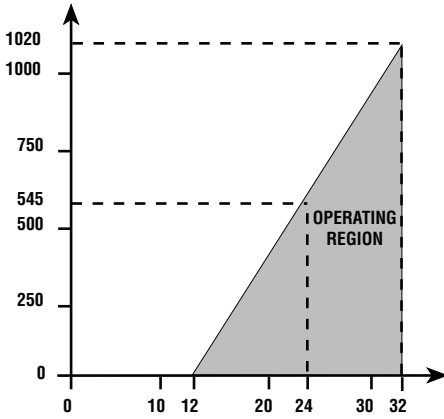

LOOP SUPPLY VOLTAGE

$$V^{\min} = 12V + [.022A * R^L]$$

*Includes a 10% safety factor

$$R^L = R^S + R^W$$

R^L = Loop Resistance (ohms)

R^S = Sense Resistance (ohms)

R^W = Wire Resistance (ohms)

