

**INSTRUCTIONS FOR THE INSTALLATION,  
OPERATION AND MAINTENANCE OF  
DIFFERENTIAL PRESSURE GAUGES**



**1. Type BC1** – Gauge has a dial with zero at top center. When the pointer is to the right of the zero it indicates that the pressure at the right hand socket connection is greater than that exerted at the left and vice-versa. The gauge will not be damaged if the highest pressure should shift from left to right or vice-versa.

**2. Type BD1** – Gauge has the usual type dial, such as 0/30, 0/100, etc., with the zero at the bottom left. Pressure must be applied to the high pressure connection before the low pressure is applied. It is important that the high pressure line be connected to the right hand socket, (marked “H”).

**3. General Information** – The pressure gauge contains two bourdon tubes, the free ends of which move when subjected to pressure. A gear movement transmits the motion of the bourdon tubes to the pointer. A pressure gauge must not be subjected to a pressure higher than the maximum working pressure shown on the dial. If higher pressures are applied, permanent distortion of the bourdon tube and inaccurate readings may result. For best service the gauge should operate at approximately one half of the maximum working pressure.

*(Example: A gauge with a dial range of 0-200 psi should operate at a working pressure of about 150 lbs. or less.)*

**4. Installation** – Pressure gauges should be mounted in a vertical position and free from vibration. The gauge socket is equipped with standard size wrench flats. These wrench flats should be used exclusively when installing the gauge. Under no circumstances should any force be applied to the gauge case directly. Twisting of the case may result in disturbing the calibration of the gauge.

**5. Applications** – For steam pressure applications use a siphon. If the gauge is installed above the point of measurement, install the siphon in the pressure line to the gauge. Install a shut-off cock between the siphon and the gauge. The siphon should be filled with water to prevent steam from entering the gauge, otherwise the high steam temperature may damage the instrument. If the gauge is located below the point of measurement, the bourdon tube will be filled with condensate and no siphon is required. If the gauge is installed on a liquid pressure line, lay the piping so as to avoid vapor entrapment, otherwise readings may be incorrect. If possible, arrange for vents at high points in the line to bleed off entrapped vapors.

**6. Gauge Protectors and Dampeners** – On installations which are subject to severe pressure fluctuation, pulsations and/or line shock, the use of snubbers or orifice pulsation dampeners is recommended. Weksler pressure snubbers are available in three types for three classes of service; with oil, water and gases. The snubber is placed in the line just before the pressure gauge.

The pointer moves across the gauge scale at a rate which is proportional to the pressure differential across the element. A moderate but smooth action is obtained, free from shock and pulsation. Gauge failure due to pressure shock is eliminated. A simpler but less effective protective dampening device consists of a restrictive orifice screw. The screw is available as an accessory when ordering the gauge.

**7. Zero Adjustment** – First remove the bezel or retaining ring and glass face in order to reset the pointer. There are two types of adjustable pointers. The micrometer type is adjusted by holding the pointer firmly with one hand and rotating the adjustment screw with a small screw driver. The friction type adjustable pointer is reset by holding the pointer firmly and rotating the slotted hub with a screw driver. Plain pointers must be removed with a hand jack. On Weksler gauges equipped with plain pointers, minor adjustments can be made by rotating the slotted scale. When resetting pointers to zero, it is important that there be no pressure in both inlets.

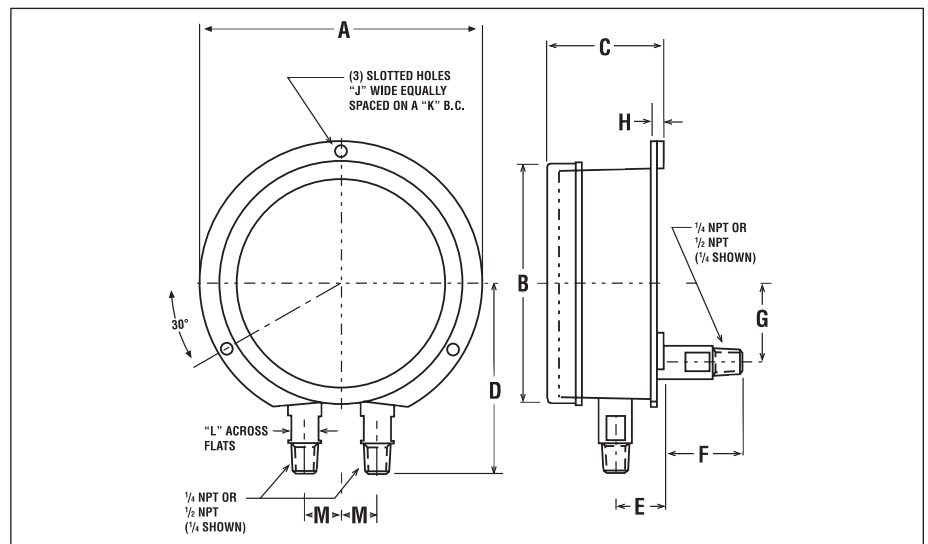

| Size Inches | A     | B                               | C                              | D                               | E    | F    | G    | H    | J    | K                               | L    | M    |
|-------------|-------|---------------------------------|--------------------------------|---------------------------------|------|------|------|------|------|---------------------------------|------|------|
| 4½          | 5⅞    | 4 <sup>31</sup> / <sub>32</sub> | 2 <sup>7</sup> / <sub>16</sub> | 3 <sup>15</sup> / <sub>16</sub> | 1    | 1⅝   | 1⅝   | 5/16 | 7/32 | 2 <sup>11</sup> / <sub>16</sub> | 9/16 | ¾    |
|             | (149) | (126)                           | (62)                           | (100)                           | (25) | (41) | (41) | (8)  | (6)  | (68)                            | (14) | (19) |

( ) are millimeters