

MOUNTING INSTRUCTIONS FOR ASHCROFT® TYPE 1009 FRONT FLANGE (XFF)

FRONT FLANGE: KIT 101A164-03 (2½") & 101A164-04 (3½")

Assemble the flange to the case with the (2) machine screws. Tighten securely (16-20in-lbs torque). Slip gauge into panel and secure using (3) screws (not supplied). Tighten securely (10in-lbs torque) for the #6 fasteners, (25in-lbs) for the #10.

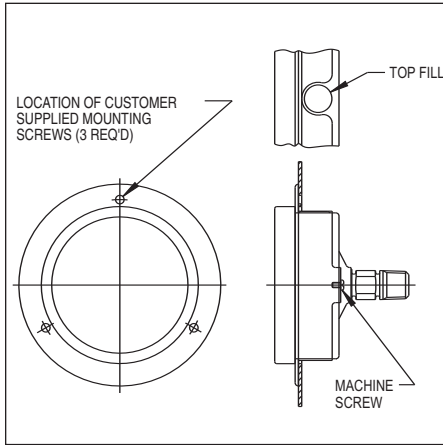

Kit	Panel Hole		Bolt Circle	Screw Hole Size	Screw Size
	Min	Max			
101A164-03 (25-1009)	2¾ (70mm)	2 ²⁵ / ₃₂ (71mm)	3⅛ (79,4mm)	.150 (3,8mm)	6
101A164-04 (35-1009)	3⅝ (92mm)	3 ¹¹ / ₁₆ (94mm)	4 ⁹ / ₁₆ (115,9mm)	.220 (5,6mm)	10

I&M008-10114 (83A209-01 REV B) AMR 7/07

MOUNTING INSTRUCTIONS FOR ASHCROFT® TYPE 1009 BACK FLANGE (XFW)

BACK FLANGE: KIT 101A164-05 (2½") & 101A164-06 (3½")

Assemble the flange to the case with the (2) machine screws. Tighten securely (16-20in-lbs torque). Place gauge against surface and secure using (3) screws (not supplied). Tighten securely (10in-lbs torque) for the #6 fasteners, (25in-lbs) for the #10.

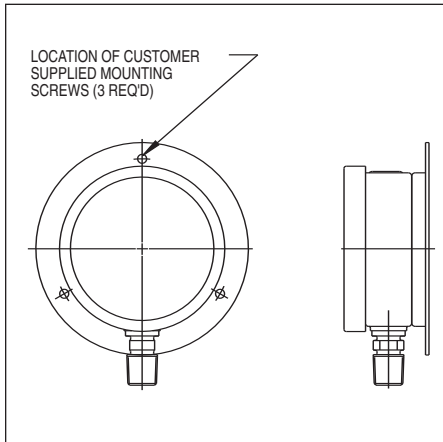

Kit	Bolt Circle	Screw Hole Size	Screw Size
101A164-06 (35-1009)	4 ⁹ / ₁₆ (115,9mm)	.220 (5,6mm)	10

I&M008-10115 (83A210-01 REV B) AMR 7/07

MOUNTING INSTRUCTIONS FOR ASHCROFT® TYPES 1009, 1008 & 3005 U-CLAMP (XUC)

U-CLAMP: KIT 101A164-01 (2½", 63mm) & 101A164-02 (3½", 100mm)

Assemble the (2) 1 inch long set screws to the rear of the case. Tighten finger tight. Slip gauge into panel and assemble U-clamp over the set screws. Secure the U-clamp with (2) lockwasher nuts using a 1¹/₁₆ wrench (16-20in-lbs torque).

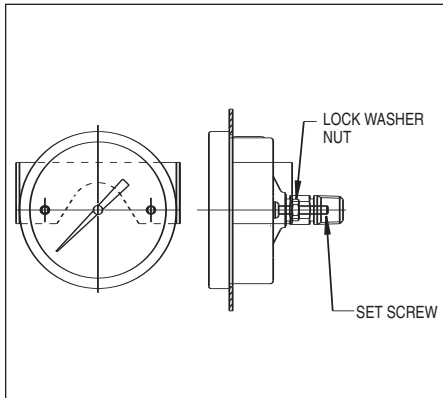

Kit	Panel Hole	
	Min	Max
101A164-01 (25-1009)	2¾ (70mm)	2 ²⁵ / ₃₂ (71mm)
101A164-02 (35-1009)	3⅝ (92mm)	3 ¹¹ / ₁₆ (94mm)
101A164-01 (63-3005) (63-1008)	2 ¹⁷ / ₃₂ (64mm)	2 ⁹ / ₁₆ (65mm)
101A164-02 (10-1008)	3 ³¹ / ₃₂ (101mm)	4 (102mm)

I&M008-10116 (83A213-01 REV D) AMR 7/07

MOUNTING INSTRUCTIONS FOR ASHCROFT® TYPES 1008 & 3005 FRONT FLANGE (XFF)

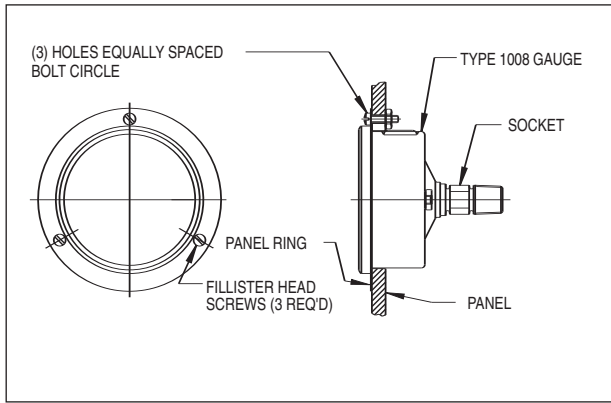

1. Drill panel hole for gauge (see table for size).
2. Drill 3 mounting screw holes on bolt circle per table.
3. At customer's option: for tighter gauge/panel fit slip sponge-rubber gasket (supplied) over back of gauge flush to case ring.
4. Assemble gauge into panel hole.
5. Place panel ring over gauge and secure to panel with screws and nuts provided.

Kit	Panel Hole		Bolt Circle	Screw Hole Size	Screw Size
	Min	Max			
101A140-03 (63-3005) (63-1008)	2 ¹⁷ / ₃₂ (64mm)	2 ⁹ / ₁₆ (65mm)	2.95 (75mm)	.150 (3,8mm)	6-32
101A140-04 (10-1008)	3 ³¹ / ₃₂ (101mm)	4 (102mm)	4.57 (116mm)	.190 (4,8mm)	8-32

I&M008-10117 (83A212-01 REV B) AMR 7/07

MOUNTING INSTRUCTIONS FOR ASHCROFT® TYPES 1009, 1008 & 3005 RETRO-FIT (XRF)

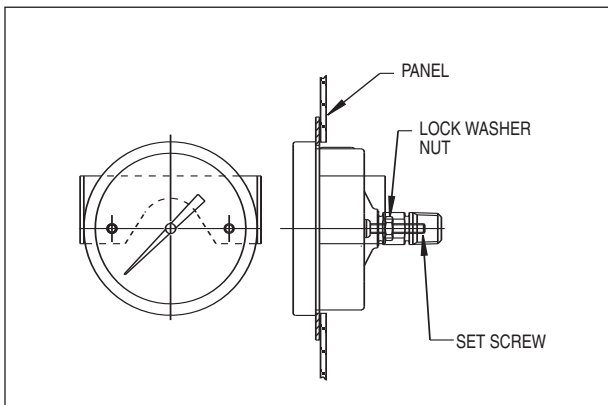

Assemble the (2) 1 inch long set screws to the rear of the case using a ⁵/₆₄ allen wrench. Tighten securely (16-20in-lbs torque). Slip ring over case back before inserting gauge into panel. Assemble U-clamp over set screws. Secure the U-clamp with (2) lockwasher nuts using a ¹¹/₃₂ wrench (16in-lbs torque).

Kit	Panel Hole	
	Min	Max
101A140-06 (63-3005) (63-1008)	2 ¹⁷ / ₃₂ (64mm)	2 ⁹ / ₁₆ (65mm)
101A140-07 (10-1008)	3 ³¹ / ₃₂ (101mm)	4 (102mm)
101A140-08 (35-1009)	3 ⁵ / ₈ (92mm)	3 ¹¹ / ₁₆ (94mm)

I&M008-10118 (83A216-01 REV C) AMR 7/07