

**PRODUCT INFORMATION****INTRODUCTION**

Pressure fittings are available in a wide variety of sizes and configurations. The most commonly used connection in North America is the “National Pipe Thread” (NPT), which creates a seal by the intermeshing of the threads along a tapered thread line. Since this method can still allow a leak path between the thread crests and roots, the application of a thread sealer is required, in the form of Teflon® tape or a hardening liquid chemical compound referred to as “pipe dope”. However, process interface requirements, dynamic forces and differing international standards often preclude the use of NPT fittings in favor of more sophisticated pressure connections. Among the various alternatives are fittings that form the pressure seal through the use of an O-ring, gasket or metal-to-metal compression assembly. But despite the many application-specific connection requirements, the most compelling divergence from NPT is the need to contain higher pressures.

**THE HIGH PRESSURE SEAL**

“High pressure” is a relative term. Depending on the user’s perspective, high pressure may be defined as low as 200 and as high as 60,000 psi. For the purposes of this discussion, we will refer to high pressure as any pressure outside the maximum sealing capacity of an NPT fitting, which is approximately 20,000 psi.

With NPT unable to contain higher pressures, a stronger, better sealing fitting, designed specifically for high pressure will be required. Depending on the pressure level, there are several different types to choose from. However, in instrumentation, the most common is the 1/16”-18 UNF-2B female port for 1/4” O.D. high pressure tubing (often designated by the brand reference “Autoclave F-250-C”). The inlet itself is a very simple female straight-thread port, distinguishable by its interior flat bottom with a counter-sunk pressure passage hole in the center. To installers who are unfamiliar with this connection, the first step will be to ask the question: “when installing the instrument, what type of (male) fitting does it mate to?”

In fact, the mating connection is not a single fitting, but a three part assembly. Since high pressures cannot be contained with conventional piping or hoses, special high pressure, thick walled 1/4” O.D. tubing often serves as the necessary conduit. Thus, to form a seal capable of containing high pressures, a metal-to-metal seal must be established whereby **the tip of the tubing is forced into a counter-sink (seat) at the opening of the pressure passage hole inside (at the bottom of) the female port.** To achieve this, a “compression fit” must be created through the use of three components: 1) the system’s high pressure tubing, prepared with a 59° chamfered tip and left hand thread, 2) the collar (sleeve) and 3) the gland nut. Assembled properly, tightening the gland into the female port will exert pressure on the collar, thus forcing the tip of the tubing into the seat at the bottom of the female port and thereby creating the high pressure seal (see Figures 2 and 3).

In rare cases where an instrument may be equipped with the 1/16”-18 high pressure female port but is to be used in a lower pressure application, solid adaptors designed to simulate the tubing/collar/gland assembly are available to yield a 1/4 NPT male or female inlet. (See Figure 1 for suppliers and part numbers).

## TUBE PREPARATION AND ASSEMBLY

To create the mating tube/collar/gland assembly, the tubing tip must first be formed and the fitting components must be assembled per the following steps:

1. To prepare the tubing, two operations are required:
  - A) "Coning" the tube tip:** The tip of the high pressure tubing must first be "coned" or "beveled" to a 59° angle to produce the tube's sealing surface. (See Figure 2). This can be accomplished by the use of a lathe or special coning tools offered by the component suppliers (see figure 1).
  - B) Threading the tubing:** A ¼-28 UNF-2A left hand thread (See Figure 2) must be turned onto the end of the tubing. Special tools and dies are also available specifically for this operation.
2. Slide the gland nut over the tubing so that the male threads face the open end of the tube.
3. Thread the female collar onto the left hand threads on the tubing.
4. Slide the gland nut down over the collar.
5. Insert the entire assembly into the female port of the gauge so that the coned end of the tubing seats into the countersink (seat) inside the female port.
6. Engage the ⅙" male threads of the gland nut into the female threads of the instrument's port. As the gland nut is tightened, it will exert pressure upon the collar, forcing the coned tip of the tubing into the seat.
7. If the tubing appears to be loose inside the assembly, back out the gland nut and remove the assembly from the instrument port. Turn the collar counter-clockwise so that it is positioned farther up the tubing (away from the tip) so that the coned end of the tubing protrudes farther out (away from) the gland nut. Conversely, if the tube is protruding out so far that the gland nut cannot engage at least 4 complete threads, turn the collar clockwise to shorten the distance that the tubing tip protrudes away from the gland nut. When properly adjusted, return to step 6.

### SUPPLIERS

Tubing, gland nuts, collars, adaptors and tools are offered by the following suppliers. (Some may refer you to a local distributor.)

#### **Autoclave Engineers, Inc.**

2930 W. 22nd Street  
Box 5051  
Erie, PA 16512-5051  
814/838-2071 Fax: 814.860.5811  
www.autoclaveengineers.com

#### **Newport Scientific, Inc.**

(Formerly AMINCO),  
"Superpressure" Line  
8246-E Sandy Court  
Jessup, MD 20794-0189  
301/498-6700 Fax: 301/490-2313  
www.newport-scientific.com

#### **BuTech Pressure Systems**

2121 EBCO Drive, Suite 1  
Erie, PA 16506  
814/833-4904 Fax: 814-833-2612  
www.butech-valve.com

#### **High Pressure Equipment Company (HIP)**

P.O. Box 8248, 1222 Linden Avenue  
Erie, PA 16505  
800-289-7447 Fax: 814-838-6075  
www.highpressure.com

#### **The Swagelok Company (Sno-Trik®)**

2950 Solon Road  
Solon OH 44139  
see website for local distributor  
www.swagelok.com

**FIGURE 1  
PART NUMBER CROSS REFERENCE GUIDE FOR 1/4" HIGH PRESSURE  
TUBING FITTING COMPONENTS AND ACCESSORIES**

Item	Autoclave	Newport	BuTech	HIP	Sno-Trik®
Gland Nut or	AGL 40	45-11313 or	60G4	60-2HM4	-
		45-11314			
Collar	ACL 40	45-11316 or	60C4	60-2H4	-
		45-11317			
Coning Tool	401A	48-15013	60CT4	2-HF4	MS-469-CT
Threading Tool	402A	48-15025	THT4-H	2-MHF4	-
HP Male to 1/4 NPT-M Adapter	-	45-16370	MA4H4P	30-21HM4NMB	SS-44M-1-4
HP Male to 1/4 NPT-F Adapter	15M94B8	45-16705	10A4H4P	30-21NFBHM4	SS-44M-7-4
Also sells HP Tubing	Yes	Yes	Yes	Yes	Yes

**Notes:**

- 1) Abbreviation "HP" = High Pressure
- 2) All gland nuts, collars and adapters identified above are 316 SS except: Newport - Top P/N designates 416 SS (bottom P/N designates 316 SS) HIP - Standard material for gland nuts and collars is 17-4PH Nickel. 316 SS is optionally available under the same P/N.
- 3) Newport (AMINCO) also offers the gland nut and collar set under a single P/N; 45-11310.
- 4) All coning and threading tools are complete sets which include all necessary dies and cutting bits.
- 5) Autoclave also sells tube bending equipment.
- 6) Autoclave and Butech also sell motorized threading machines.
- 7) When ordering gland nuts, collars, adapters and tubing, be sure to specify your maximum working pressure requirement because maximum allowable working pressure ratings for components may vary among manufacturers.

**FIGURE 2**

**1/4" HIGH PRESSURE TUBING ASSEMBLY  
(EXPLODED)**

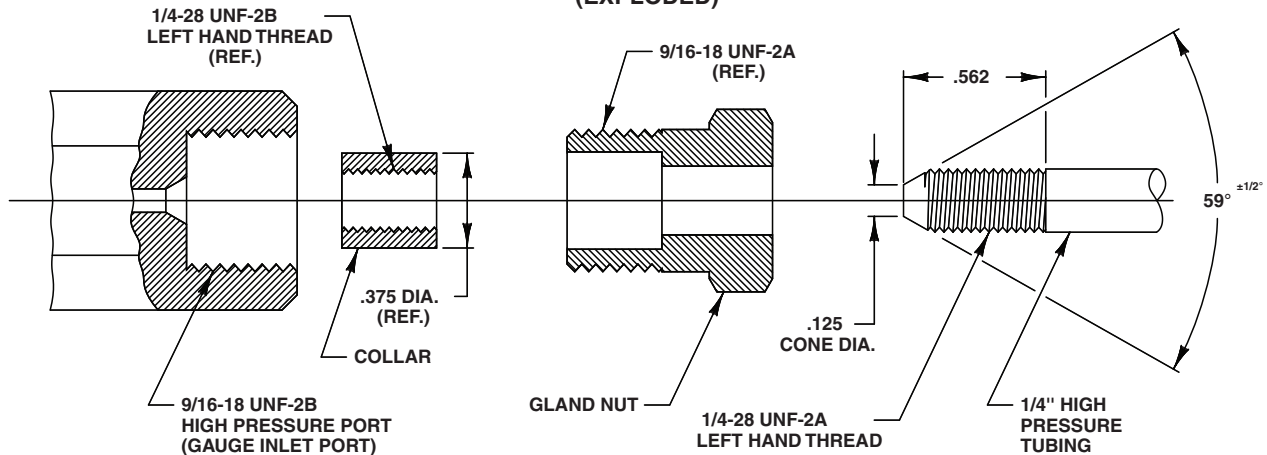

**FIGURE 3**

**1/4" HIGH PRESSURE TUBING ASSEMBLY  
(ASSEMBLED)**

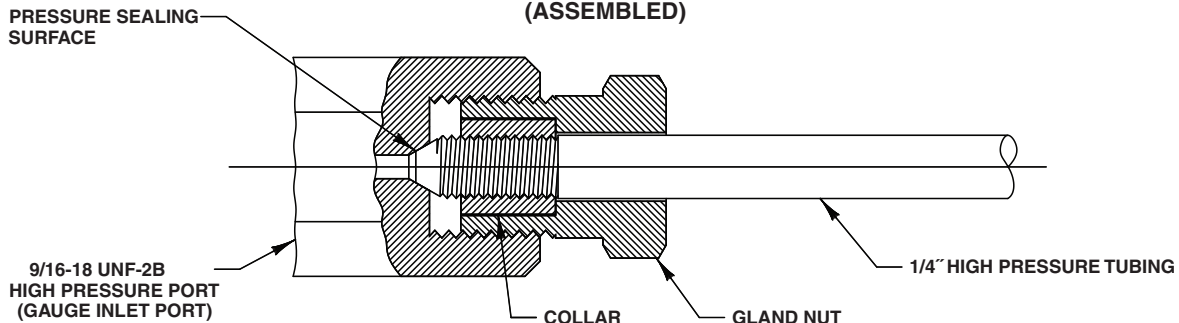

TUBE ASSEMBLY REV. 3

<b>Figure 4</b> <b>High Pressure Tubing Specification</b> <b>(Typical) 316 Stainless Steel</b>		
<b>Maximum Work- ing Pressure</b> <b>@ 72°F</b>	<b>O.D.</b>	<b>I.D.</b>
20,000 psi	1/4"	.109"
60,000 psi	1/4"	.083", .094"
100,000 psi	1/4"	.0625"

Teflon® is a registered trademark of the E. I. du Pont de Nemours and Company  
Sno-Trik® is a registered trademark of the Swagelok Company.

**Notes:**

- 1) Some vendors offer alternate tubing materials. I.D. dimension may vary with material.
- 2) Some manufacturers classify 20,000 psi as "medium" pressure tubing.

Ashcroft Inc. July/25/08 Rev. 2