

320 Flush Quick-Connect Diaphragm Seal

FEATURES

- All-welded construction
- Easy dismantling and reassembly
- Compatible with Tri-Clover and Cherry Burrell® S line connection

TYPICAL USES

- Pharmaceutical
- Biotech
- Food & Beverage



320
Quick-Connect Seal

SPECIFICATIONS

Connection style:	320 Quick-Connect
Process Connection:	1½", 2"
Instrument Connection:	¼ or ½ NPT Female
Pressure Rating (MAWP):	1½": 1,500 psi 2": 1,000 psi
Added Tolerance:	±0.5% typical
Fill Fluid:	See table 1 on page 2

WETTED COMPONENTS

Diaphragm:	316L Stainless steel
------------	----------------------

NON-WETTED COMPONENTS

Top Housing:	316L Stainless steel
--------------	----------------------

KEY BENEFITS

- Compact, lightweight design
- Simple installation using customer-supplied clamp rings
- Flush diaphragm eliminates clogging
- Minimal fill volume reduces temperature error

320 Flush Quick-Connect Diaphragm Seal

ORDERING CODE	Example:	15	320	SX	02T	XCG	NH
Process Connection Size							
15 - 1½" Quick-connect		15					
20 - 2" Quick-connect							
Seal Type							
320 - Quick Connect Seal			320				
Diaphragm Material							
SX - 316L Stainless steel				SX			
Instrument Connection Size							
02T - ¼ NPT Female					02T		
04T - ½ NPT Female (only available on 2" Quick-connect process connection)							
Options (if choosing option(s) must include an "X")						X__	
Fill Fluid (See Table 1 above for more available fill fluids)							
CK - 50 cSt Silicone							
Optional Features							
NH - Stainless steel instrument tag							NH
MQ - Positive material identification							

When selecting an instrument, refer to the [Min/Max Guide](#) for compatibility with this diaphragm seal or scan the QR code to the right.



320 Flush Quick-Connect Diaphragm Seal

TABLE 1 - FILL FLUIDS

Fill Fluid	Temperature	Viscosity (cSt at RT)	Variation Code	Notes
Glycerin (food grade)	0°F to 400°F (-18°C to 204°C)	1,300	CG	Direct-mounting only. Not for use with vacuum service
50 cSt Silicone	-40°F to 500°F (-40°C to 260°C)	50	CK	
10 cSt Silicone	-40°F to 500°F (-40°C to 260°C)	10	DJ	
Halocarbon® 4.2	-70°F to 300°F (-57°C to 199°C)	4.2	CF	For use with oxygen/oxidizing process media
Slytherm® 800	-40°F to 750°F (-40°C to 400°C)	10	HA	High temperature applications
Syltherm® XLT	-150°F to 500°F (-100°C to 260°C)	1.4	CC	Low temperature applications
Calflo® AF	-20°F to 600°F (-29°C to 316°C)	60	KF	High temperature, silicone-free
Mineral Oil	10°F to 400°F (-12°C to 204°C)	75	MY	
Neobee® M-20 (food grade)	5°F to 400°F (-15°C to 204°C)	9.5	NM	
Silicone (food grade)	-40°F to 500°F (-40°C to 260°C)	350	CZ	
Distilled Water	40°F to 185°F (4°C to 85°C)	0.9	FJ	
50/50 Glycerin/Water	15°F to 200°F (-9°C to 93°C)	30	GH	
Propylene Glycol	-50°F to 325°F (-46°C to 163°C)	54	CV	
Ethylene Glycol	20°F to 325°F (-7°C to 163°C)	14	FK	
50/50 Ethylene Glycol/Water	-25°F to 190°F (-32°C to 88°C)	2.9	CT	
80/20 Glycerin/Water	15°F to 225°F (-9°C to 107°C)	270	GR	
95/5 Water/Propylene Glycol	40°F to 185°F (4°C to 85°C)	1.0	PY	

DIMENSIONS in [] are millimeters

For reference only, consult Ashcroft for specific dimensional drawings

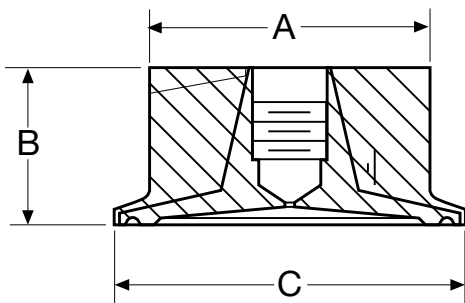

Size	A	B	C
1½"	1.66 [42]	0.88 [22]	2.00 [51]
2"	2.00 [51]	1.13 [29]	2.50 [64]