

# MODEL AXL PRESSURE TRANSDUCER INSTALLATION & MAINTENANCE SHEET



## WARNING! READ BEFORE INSTALLATION



### 1. GENERAL:

A failure resulting in injury or damage may be caused by excessive overpressure, excessive vibration or pressure pulsation, excessive instrument temperature, corrosion of the pressure containing parts or other misuse. Consult Ashcroft Inc., Stratford, Connecticut, USA before installing if there are any questions or concerns.

### 2. OVERPRESSURE:

Pressure spikes in excess of the rated overpressure capability of the transducer may cause irreversible electrical and/or mechanical damage to the pressure measuring and containing elements.

### 3. STATIC ELECTRICAL CHARGES:

Any electrical device may be susceptible to damage when exposed to static electrical charges. To avoid damage to the transducer the operator/installer should follow proper ESD (electrostatic discharge) protection procedures before handling the pressure transducer.

### 4. DESCRIPTION

The Ashcroft® AXLdp is a low differential pressure transducer to be used on clean, dry, non-corrosive gases. It is available in two accuracy classes. The transducer's accuracy is denoted by the third position of the production code. A 7 in the third position distinguishes a 1.0% accuracy transducer from a 2% accuracy transducer which would be notated with a 9 in the third position of the product code. Both unidirectional (e.g. 0 to +1.0 IW) or bi-directional (e.g. -0.10 IW to +0.10 IW) models are available. The AXLdp is only available with a ratiometric output; the transducer's output signal will be a ratio of the transducer's input voltage. At 0% of full scale the transducer will have an output of 10% of its input voltage and at 100% of full scale the transducer will have an output of 90% of its input voltage.

If the transducer is powered with a 5 Vdc supply then the transducer will have an output of 0.5 Vdc at 0% F.S. and 4.5 Vdc at 100% F.S.

### 5. SPECIFICATIONS:

**Accuracy:** Two options specified at time of order.

- $\pm 2.0\%$  Full Span at 70 °F  
o  $\pm 0.08$  Vdc for a 0.5 to 4.5 Vdc ratiometric output and a 5 Vdc supply voltage
- $\pm 1.0\%$  Full Span at 70 °F  
o  $\pm 0.04$  Vdc for a 0.5 to 4.5 Vdc ratiometric output and a 5 Vdc supply voltage

**Output:** 0.5 to 4.5 Vdc ratiometric output when powered with a 5 Vdc supply voltage

**Supply Voltage:** 4.5 to 5.5 Vdc regulated power supply

#### Electrical Connection:

- Transducer connector: JST SM03(4.0)B-BHS-1-TB
- Mating connector: JST BHR-03VS-1
- Optional electrical connection: JST BHR-03VS-1 connector with 15.75", 24 AWG leads.

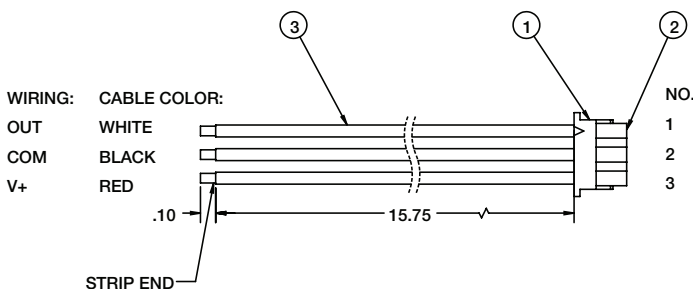

**Short-term reverse wiring protected - including temporary miswiring of the output pin**

**Operating Temperature:** -4 °F to 140 °F

#### Enclosure:

- Polybutylene Terephthalate (PBT)
- UL 94-V0 compliant
- IP20 / NEMA Type 1

#### Weight:

About 0.35 oz without optional connector and 15.75" leads

### 6. MOUNTING:

- The transducer can be mounted with a #6 or #8 screws using the 4 mounting holes provided. Torque limits on the mounting holes provided are 6" - pounds.

#### Electrical Wiring:

Ashcroft recommends the use of optional wiring harness with its 15.75", 24 AWG leads with the mating JST BHR-03VS-1 connector.

- If optional wiring harness is not being used the following JST parts are recommended:

- JST BHR-03VS-01 female connector
- JST SBH-001T-P0.5 terminal crimp
- 24 AWG wire

#### c. Connect:

- PIN 1 to the Output
- PIN 2 to the Common (V-) 1
- PIN 3 to the Supply (V+)

#### Set Up:

**Note:** For best immunity from EMI the pressure connection fittings on the AXLdp should not be grounded.

The transducers are calibrated at the factory in the vertical position. Mounting in the horizontal position can cause a zero shift of up to 1% of F.S. Please consult the factory if your application requires a horizontal sensor calibration.

To find true zero differential pressure, pneumatically connect the high and low pressure connections together using the tubing provided with the transducer. The barbed connection accepts 1/8" O.D. 1/16" I.D. tubing.

#### Routine Maintenance:

The AXLdp is a very stable and reliable transducer incorporating a proven, micro-machined silicon capacitive sensor and an application specific integrated circuit (ASIC). All calibration and temperature compensation functions are done with a microprocessor and digital routines at the time of calibration.

If questions or concerns need to be addressed, our Low Pressure Product Manager or Engineering Personnel can be contacted at 203-378-8281 or visit our website at [www.ashcroft.com](http://www.ashcroft.com).

**MODEL AXL PRESSURE TRANSDUCER  
INSTALLATION & MAINTENANCE SHEET**

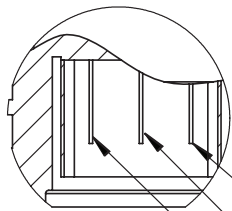
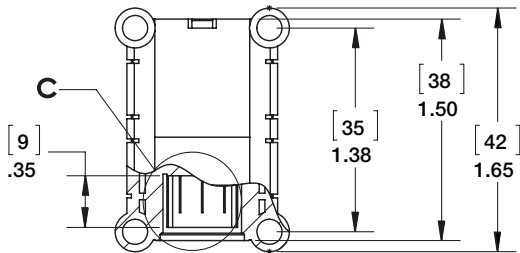
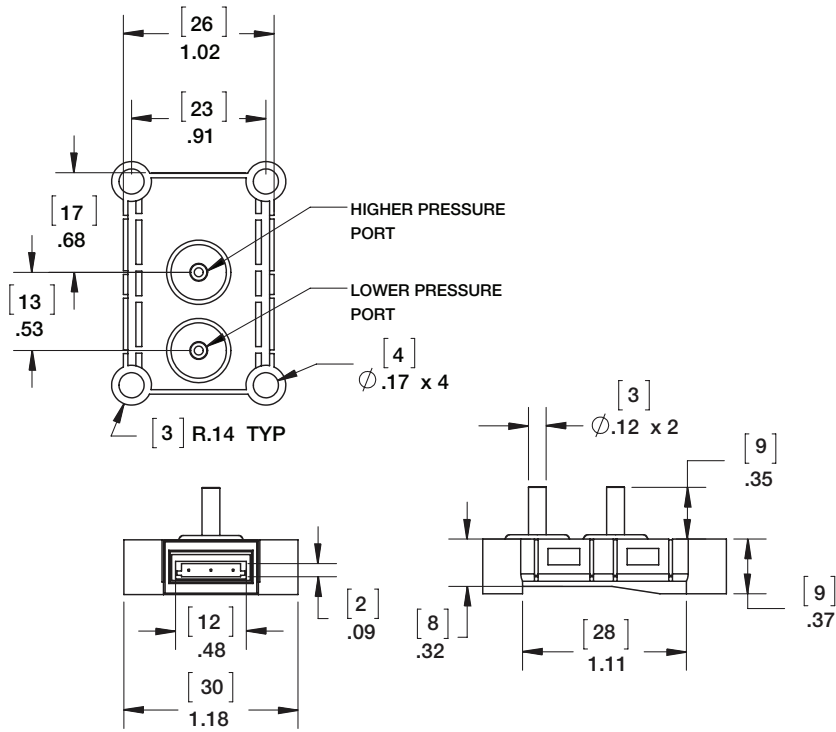

**DETAIL C  
SCALE 2 : 1**