

ASHCROFT®

Installation and Maintenance Manual for the ASHCROFT® Type 1305D Deadweight Tester and Type 1327D Portable Pump

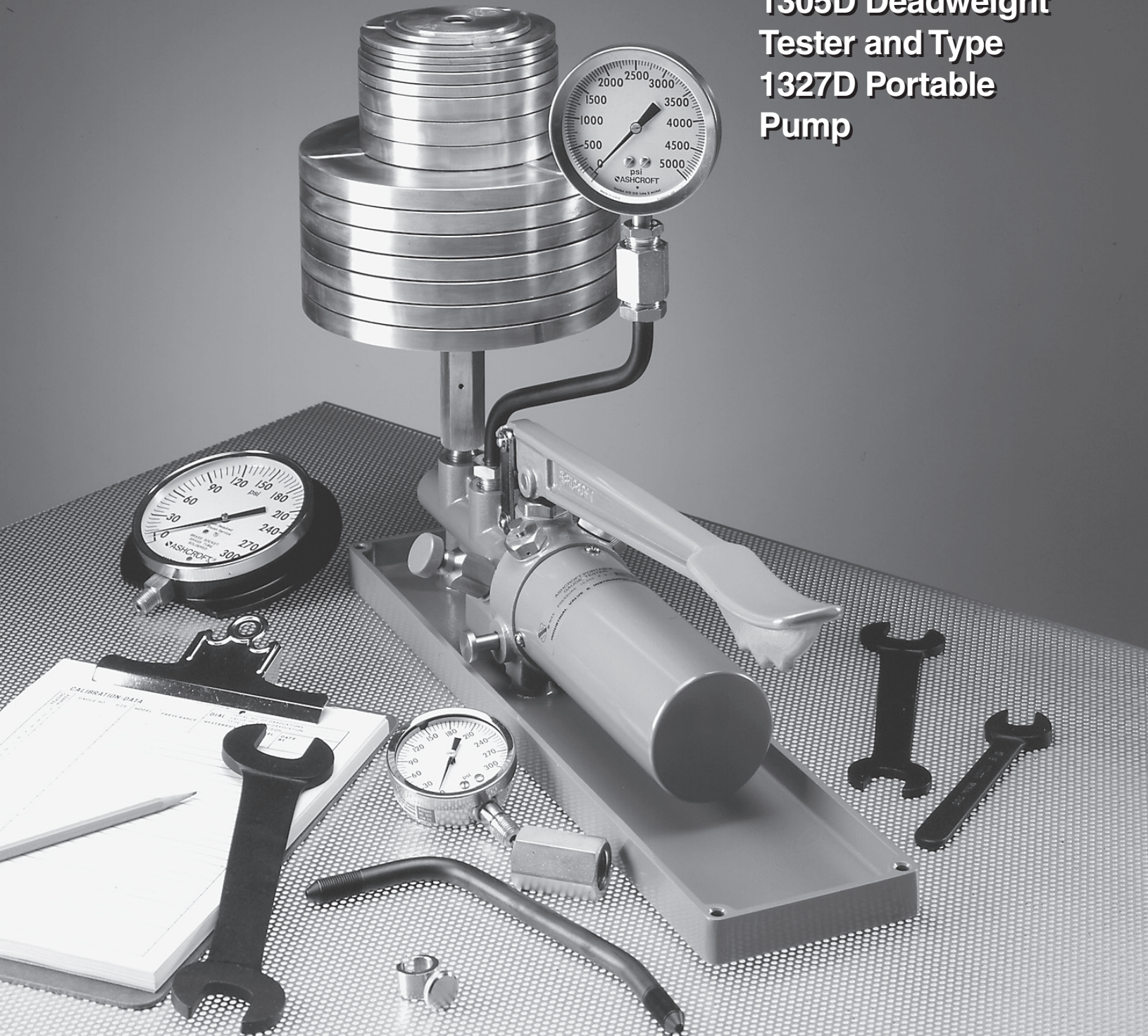

INDEX

Section Description

1. Scope of Manual Safety Precautions
2. Product Description 1305
Theory of Operation
Construction
Specifications

Product Description 1327
Theory of Operation
Construction
Specifications
3. Inspection
Installation 1305
Operation 1305
Installation 1327
Operation 1327
4. Factors Affecting Operation of Deadweight Testers
 5. Maintenance Instructions
 6. Warranty
Shipping Instructions
List of Illustrations

Figure 1-1
Figure 1-2
Figure 2-1
Figure 2-2
Figure 5-1

1.0 PURPOSE AND SCOPE OF MANUAL

This manual is provided to guide users of Model 1305D and 1327D pressure testing devices in:

- (1) installing the equipment
- (2) Routine operations

The instructions in this manual are designed to be performed by qualified instrument maintenance personnel.

Ashcroft Inc. does not recommend troubleshooting or repairs beyond the scope of this manual. Problems that cannot be remedied by following the instructions in this manual should be referred to the manufacturer. Immediate assistance can often be supplied by telephone. Defective components will be repaired or replaced by the manufacturer at his discretion and will be returned to the user by the same mode of shipment. Airmail or air express is recommended for urgent shipments. Returned goods should be accompanied by information requested in Section 6.

Contact Customer Service at:

Ashcroft Inc.
250 East Main Street
Stratford, CT 06614
Phone: (203) 378-8281
Fax: (203) 385-0402
www.ashcroft.com
email: info@ashcroft.com

1.1 Safety Precautions

Pressure Testing Equipment must be selected and used in accordance with recognized industry codes and safety practices to avoid the possibility of misuse or misapplication which could result in personal injury or property damage. Personnel responsible for selection and installation should also be familiar with the safety recommendations of ASME B40.1 that apply to elastic pressure elements and their application in general and specific services. ASME B40.1 is available from:

ANSI	or	ASME
1430 Broadway		345 47th Street
New York, NY 10018		New York, NY 10017

1. Pressure – Select a range so that the maximum applied pressure will never exceed the upper range limit.

2. Vibration – Excessive vibration could cause a loosening of components and abnormal wear resulting in loss of instrument accuracy or failure to provide valid data.

3. Temperature – Operation of the instrument in an environment where temperatures are in excess of design ratings may result in loss of accuracy and failure.

4. Process – Pressure boundary materials must be resistant to the process media. Failure to assure compatibility may result in pressure boundary deterioration or failure. Instruments operated at high pressure or with potentially hazardous service, such as oxygen, should be carefully selected in accordance with recognized industry codes and the recommendations of ASME B40.1.

2.0 PRODUCT DESCRIPTION – THEORY OF OPERATION – CONSTRUCTION

2.1.2 Product Description

2.1.3 Construction

The Ashcroft Type 1305D Dual Range Deadweight testers are precision built primary pressure standards, used for testing, setting, calibrating or repairing pressure measuring devices within the test points 15 psi (100kPa) to 10,000 psi (70,000kPa).

The deadweight tester consists of a two stage hydraulic pump containing a manifold which is pressurized during operation. Integral to the pump is a shuttle valve that allows the operator to regulate the speed of pressure increase. One connection to the manifold includes a cylinder and a free-floating precision machined piston with a plate for holding calibrated weights. A second connection to the manifold accommodates a gauge or other pressure measuring device to be calibrated or checked. Incorporated into the manifold is a hand operated displacement valve that allows small adjustments in fluid volume to be made without further operation of the pump handle or release valve.

The tester is dual range having two interchangeable piston and cylinder assemblies. One is a low pressure piston having an effective area five times larger than that of the high pressure piston. The low pressure piston is used for making measurements below 2,000 psi (14,000 kPa). The high pressure piston, with an area 1/5 that of the low pressure piston, is used to measure pressure through 10,000 psi (70,000 kPa). The weight masses are pre-measured and identified with the pressure values they produce when operated with the interchangeable piston and cylinder assemblies.

Pressure calibration points produced by the deadweight tester are accurate to within $\pm 0.1\%$ of the reading certified traceable to the N.I.S.T. The tester provides consistent, repeatable accuracy, maintaining its pressure for an appreciable length of time regardless of temperature changes, slight leaks in the pressure system, or changes in volume of the pressurized system due to movement of a Bourdon tube or other device.

A hand jack set, three wrenches, spare O-rings, and a special adapter for making connections to pressure outlets that do not accommodate cone pipe seating, are included with each unit.

All deadweight testers are supplied with lower and back connection offset pipe assemblies, with pipe adapters for $\frac{1}{4}$ NPT or $\frac{1}{2}$ NPT connections.

An all metal, double-latched, top handle carrying case is supplied with the complete tester for all fittings and attachments. Deadweights are packed in metal, double-latched storage-carrying boxes.

2.1.2 Theory of Operation – 1305D

The theory behind a deadweight tester can be expressed as simply as force acting upon a known area. Pressure produced by the pump is distributed by the manifold, to the base of a precision machined piston and to a device being calibrated or checked. Pre-selected weights loaded onto the piston platform are acted upon by gravity and develop a force that is to be equally opposed by the fluid pressure from the pump. When equilibrium is achieved, the pressure value is known, it being a direct result of the sum of the forces from the weights, piston platform and the piston divided by the effective area of the piston and cylinder assembly.

With the 1305D two piston and cylinder assemblies are supplied, one having an effective area 1/5 of the other. When using the smaller piston and cylinder assembly, five times more pressure is required to oppose the force of a constant mass being acted upon by gravity. For this reason the masses supplied with the tester are stamped with two pressure values, the value being contingent on the effective area of the piston and cylinder assembly selected.

2.1.3 Specifications – 1305D

Accuracy: Combined tolerance of weights and piston and cylinder assemblies within 0.1% of reading. Weight tolerance within 0.05% of mass. Piston and cylinder is within 0.05% of rated mean effective area.

Deadweight: Non-magnetic die cast zinc alloy. Total weight to produce maximum pressure of 10,000 psi (70,000kPa) is 125 lbs. (56.7 kg).

Piston & Cylinder Assemblies: High strength stainless steel piston and cylinder with brass collar and aluminum weight platform.

Pump: Two stage, lever operated generates 10,000 psi (70,000 kPa) with 28 pounds (12.7 kg) of force on lever handle.

Pump Body: Aluminum, corrosion inhibited and coated with baked blue epoxy finish.

Shuttle Valve: Stainless steel bypass valve that controls rate of pressure increase and reduces operator effort when working at high pressure.

Displacement Valve: A fine pitched threaded valve rod permitting vernier adjustments to fluid volume and provide precise pressure changes or adjustment of piston travel. Limit stops prevent rod removal during normal operation.

Mounting: Four bench mounting holes located in base for positive mounting to any level surface.

Instrument Connections: Two coned pipe assemblies provide vertical calibration capability for back and lower connected gauges. Standard $\frac{1}{4}$ inch internal NPT and $\frac{1}{2}$ inch inter NPT fitting adapters are supplied.

Operating Fluid: 1305D – Light grade machine oils, automotive petroleum base SAE 20 oils or other equivalent fluids suitable for use with Buna N O-ring materials. 1.5 pints required (.7 liters).

1305DH – Most hydraulic oils of phosphate ester base, brake fluids, skydrol, pydraul etc., suitable for use with Butyl or Ethylene-Propylene O-ring materials. 1.5 pints required (.7 liters).

2.1.4 Certification:

Standard (CD-3) – Traceable calibration certificate (accuracy/traceability statement only).

Optional (CD-5) – Certification document includes actual (as left) weight values for each weight and piston, piston diameter values, environmental data and test numbers. Set includes numbered weights.

2.2 Product Description 1327D

2.2.1 Construction

The Ashcroft Type 1327D Portable Test Pumps are rugged, versatile pressure transfer standards, used for testing, setting, calibrating or repairing pressure measuring devices with ranges up to 10,000 psi (70,000kPa). A selection of high accuracy test gauges, with a precision of $\pm 0.25\%$ of span, are supplied as the standard to which the device under test is compared.

The main component to the tester is a two stage hydraulic pump containing a manifold which is pressurized during operation. Integral to the pump is a shuttle valve that allows the operator to regulate the speed of pressure increase. One connection to the manifold has a straight pipe with a precision test gauge attached serving as the reference standard. A second connection to the manifold accommodates a gauge or other pressure measuring device to be calibrated or checked. Incorporated into the manifold is a hand operated displacement valve that allows small adjustments in fluid volume to be made without further operation of the pump handle or release valve.

Model Number	Piston Assembly Pressure Range		Piston Piston Area		Value		Number of Weights by Value					Net Weight		
	psi Type	Low	High	Low	High	Low	High	L-5 H-25	L-10 H-50	L-20 H-100	L-40 H-200	L-100 H-500	lbs.	kg.
1305D-10														
1305DH-10	15/200		75/1000			5	25	1	3	2	3	--	60	27
1305D-20														
1305DH-20	15/400		75/2000			5	25	1	3	2	3	2	70	32
1305D-30														
1305DH-30	15/600		75/3000	.0625 in. ² (.4032)	.0125 in. ² (.0806)	5	25	1	3	2	3	4	85	39
1305D-50														
1305DH-50	15/1000		75/5000			5	25	1	3	2	3	8	105	48
1305D-100														
1305DH-100	15/2000		75/10000			5	25	1	3	2	3	18	175	80
Model Number	Piston Assembly Pressure Range		Piston Piston Area		Value		Number of Weights by Value					Net Weight		
METRIC RANGES ARE NO LONGER AVAILABLE – INFORMATION FOR REFERENCE ONLY														
kg/cm ² Type	Low	High	Low	High	Low	High	L-.5 H-2.5	L-1 H-5	L-2 H-10	L-4 H-20	L-5 H-25	lbs.	kg.	
1305DM-20														
1305DMH-20	1/20		--			.5	2.5	1	1	2	1	2	63	29
1305DM-100														
1305DMH-100	1/20		5/100			.5	2.5	1	1	2	1	2	65	30
1305DM-150														
1305DMh-150	1/30		5/150	.0625 in. ² (.4032)	.0125 in. ² (.0806)	.5	2.5	1	1	2	1	4	75	34
1305DM-350														
1305DMH-350	1/70		5/350			.5	2.5	1	1	2	1	12	105	48
1305DM-700														
1305DMH-700	1/140		5/700			.5	2.5	2	1	2	1	26	175	80
Model Number	Piston Assembly Pressure Range		Piston Piston Area		Value		Number of Weights by Value					Net Weight		
bar Type	Low	High	Low	High	Low	High	L-.5 H-2.5	L-1 H-5	L-2 H-10	L-4 H-20	L-5 H-25	lbs.	kg.	
1305DB-20														
1305DBH-20	1/20		--			.5	2.5	1	1	2	1	2	63	29
1305DB-100														
1305DBH-100	1/20		5/100			.5	2.5	1	1	2	1	2	65	30
1305DB-150														
1305DBH-150	1/30		5/150	.0613 in. ² (.3954)	.0123 in. ² (.0791)	.5	2.5	1	1	2	1	4	75	34
1305DB-350														
1305DBH-350	1/70		5/350			.5	2.5	1	1	2	1	12	105	48
1305DB-700														
1305DBH-700	1/140		5/700			.5	2.5	2	1	2	1	26	175	80
Model Number	Piston Assembly Pressure Range		Piston Piston Area		Value		Number of Weights by Value					Net Weight		
Pascal Type	Low	High	Low	High	Low	High	L-50 H-250	L-100 H-500	L-200 H-1000	L-400 H-2000	L-500 H-2500	lbs.	kg.	
1305DA-2000														
1305DAH-2000	100/2000		--			50	250	1	1	2	1	2	63	29
1305DA-10000														
1305DAH-10000	100/2000		500/10000			50	250	1	1	2	1	2	65	30
1305DA-15000														
1305-DAH-15000	100/3000		500/15000	.0613 in. ² (.3954)	.0123 in. ² (.0791)	50	250	1	1	2	1	4	75	34
1305DA-35000														
1305DAH-35000	100/700		500/35000			50	250	1	1	2	1	12	105	48
1305DA-70000														
1305DAH-70000	100/14000		500/70000			50	250	2	1	2	1	26	175	80

Dimensions in () are square centimeters

TABLE 2-1

Pressure values produced by the pump are able to be clearly read to within $\pm 0.25\%$ accuracy of the span of the precision test gauge selected for testing. Certification of test gauge accuracy traceable to the N.I.S.T., is available upon request. A hand jack set, three wrenches, spare O-rings, and special adapter for making connections to pressure outlets that do not accommodate cone pipe seating, are included with each unit.

Test pump accessories include lower and back connection offset pipe assemblies, with pipe adapters for $\frac{1}{4}$ and $\frac{1}{2}$ NPT connections.

An all metal, double-latched, top handle carrying case is supplied with the complete tester to hold all fittings and attachments.

2.2.2 Theory of Operation – 1327D

The operating principle behind the 1327D Test Pump is a simple form of comparison. Pressure produced by the pump is equally distributed by the manifold to a test gauge and to a device being calibrated or checked. The reading of the test gauge serves as the reference to which other device readings are compared against.

Selection of the test gauge range is the determining factor in establishing the precision to which a comparison check is to be made. Test gauge accuracy is expressed as a percentage of its span.

Proper selection of the test gauge range must be made to minimize the amount of the unit error. If a 5,000 psi (35,000kPa) range test gauge were used to test devices whose span values were less than a fourth of the test gauge range, the unit error of 12.5 psi (87kPa) would be greater than 1% of the test pressure. Therefore, it is important to select a test gauge that has a full scale range equal to or only slightly in excess of the pressure value to be measured.

2.2.3 Specifications – 1327D

Accuracy: $\frac{1}{4}\%$ of 1% of test gauge span.

Test Gauges: Ashcroft solid front type 45-1082-02L-XAZ, $4\frac{1}{2}$ " dial size (120mm case). Bourdon tube materials for 1327D and DH are bronze and Monel. Bourdon tube materials for 1327DO are bronze and Monel.

Pump: Two stage, lever operated generates 10,000 psi (70,000kPa) with 28 pounds (12.7kg) of force on lever handle.

Pump Body: Aluminum, corrosion inhibited and coated with baked blue epoxy finish.

Shuttle Valve: Stainless steel bypass valve that controls rate of pressure increase and reduces operator effort when working at high pressure.

Displacement Valve: A fine pitched threaded valve road permitting vernier adjustments to fluid volume to provide precise changes. Limit stops prevent road removal during normal operation.

Mounting: Four bench mounting holes located in base for positive mounting to any level surface.

Instrument Connections: Two coned pipe assemblies provide vertical calibration capability for back and lower connected gauges. Standard $\frac{1}{4}$ inch internal NPT and $\frac{1}{2}$ inch internal NPT fitting adapters are supplied.

Operating Fluid: 1327D – Light grade machine oils, automotive petroleum base SAE 20 oils or other equivalent fluids suitable for use with Buna N O-ring materials. 1.5 pints required (.7 liters).

1327DH – Most hydraulic oils of phosphate ester base, brake fluids, skydrol, pydraul etc., suitable for use with Butyl or Ethylene-Propylene O-ring materials. 1.5 pints required (.7 liters).

1327DO – Distilled water with compatible corrosion inhibitor. A .1% solution of sodium dichromate is a suitable inhibitor. 1.5 pints required (.7 liters).

2.2.4 Certification:

Standard – Master gauges are calibrated on traceable standards, no certification documentation provided.

Optional (CD-4) – Traceable calibration certificate for each master gauge.

3.0 SETTING UP THE TESTER

3.1 Inspection

3.1.1 Component Check 1305D

The deadweight tester, as shipped from the factory, contains all of the components necessary for operation except pump fluid. Depending upon the model and pressure range selected, the total number of weights, weight boxes and piston and cylinder assemblies will vary. Refer to Specifications, Section 2.1, Table 2-1 for model clarification.

3.1.2 Component Check 1327D

The portable test pump, as shipped from the factory, contains all of the components necessary for operation except pump fluid. Depending upon the model and pressure range selected, the total number and their ranges will vary. Refer to Specifications, Section 2.2, Table 2-3 for model clarification.

3.1.3 Claim for Missing or Damaged Goods

In the event it is determined that an item is missing or damaged, contact Customer Service immediately at the address indicated in Section 1.0. Damaged merchandise and the packaging materials must be held for inspection by authorized Ashcroft Inc. personnel or the responsible carrier. Disposition of damaged or missing goods will be determined after inspection has been performed on location, or at the discretion of the manufacturer, at the factory. Inspection may be waived if circumstances, as judged by the manufacturer, preclude its necessity.

3.2 Installation Type 1305D

3.2.1 Set-up Procedure (See Figure 2-1)

To remove the tester from the case, release the spring clip, depressing the clip by hand, grasp the pump reservoir and lift up the back end of the pump assembly.

Having removed the pump assembly from its carrying case, remove the two plastic shipping plugs.

Select a lower connection (64) or back connection (66) offset pipe and connect to inner pump body outlet as shown in Fig. 2-1.

Remove the reservoir filler plug (35) and fill reservoir with operating fluid.

3.2.2 Bench Space Required (See Figure 1-1)

Allow a space:

10 inches (25.4 cm) width

27 inches (68.6 cm) depth

22 inches (55.9 cm) height – allows for maximum load of deadweights

3.2.3 Storage Space Required

One Tester Box:

$10\frac{1}{2}$ inch (2.6 cm); $22\frac{1}{2}$ inch (57 cm) depth; 10 inch (25 cm) height

Unit Of Measure	Model Number	Case	Tools & Access.	Gauge Range(s) Included				Net Weight	
								lbs.	kg
	1327* 1327H* 1327O	-	-	-	-	-	-	12	5
	1327D 1327DH 1327DO	X	X	-	-	-	-	34	15
psig	1327DG-2 1327DGH-2 1327DGO-2	X	X	0/150	-	-	-	36	16
	1327DG-6 1327DGH-6 1327DGO-6	X	X	0/150	0/600	-	-	38	17
	1327DG-50 1327DGH-50 1327DGO-50	X	X	0/150	0/600	0/5000	-	40	18
	1327DG-100 1327DGH-100 1327DGO-100	X	X	0/150	0/600	0/5000	0/10000	42	19
kg/cm2	1327DMG-10 1327DMGH-10 1327DMGO-10	X	X	0/10	-	-	-	36	16
	1327DMG-40 1327DMGH-40 1327DMGO-40	X	X	0/10	0/40	-	-	38	17
	1327DMG-250 1327DMGH-250 1327DMGO-250	X	X	0/10	0/40	0/250	-	40	18
	1327DMG-600 1327DMGH-600 1327DMGO-600	X	X	0/10	0/40	0/250	0/600	42	19
bar	1327DBG-10 1327DBGH-10 1327DBGO-10	X	X	0/10	-	-	-	36	16
	1327DBG-40 1327DBGH-40 1327DBGO-40	X	X	0/10	0/40	-	-	38	17
	1327DBG-250 1327DBGH-250 1327DBGO-250	X	X	0/10	0/40	0/250	-	40	18
	1327DBG-600 1327DBGH-600 1327DBGO-600	X	X	0/10	0/40	0/250	0/600	42	19
Pascal (kPa)	1327DAG-1000 1327DAGH-1000 1327DAGO-1000	X	X	0/1000	-	-	-	36	16
	1327DAG-4000 1327DAGH-4000 1327DAGO-4000	X	X	0/1000	0/4000	-	-	38	17
	1327DAG-25000 1327DAGH-25000 1327DAGO-25000	X	X	0/1000	0/4000	0/25000	-	40	18
	1327DAG-60000 1327DAGH-60000 1327DAGO-60000	X	X	0/1000	0/4000	0/25000	0/60000	42	19

*Includes Test Pump Only

TABLE 2-2

One Weight Box:

10 inch (25 cm) width; 10 inch (25 cm); 10 inch (25 cm) height

Storage space dimensions are larger than actual size of tester carrying case and deadweight carrying case by approximately $\frac{1}{2}$ inch, (1.3 cm), in order to facilitate ease of handling in storage.

Note: For catalog numbers 1305D, DH-100, 1305DM, DMH-150, 1305DB, DBH-700 and 1305DA, DAH-700 allow storage space for two weight boxes.

3.3 Operation 1305D**3.3.1 Piston and Cylinder Selection**

The 1305D Tester is a dual range device in that most -models utilize two interchangeable piston and cylinder assemblies for measurement of pressure throughout the entire range. Each piston and cylinder assembly has a minimum and maximum operating range. First, determine what pressure points need to be measured and select the appropriate assembly. The pressure range of the assemblies is shown in Table 2-1. When priming the pump the high pressure piston and cylinder assembly should be used.

3.3.2 Priming the Pump

The offset pipe (64 or 66 Figure 2-1) should already be secured in place and the reservoir should contain the operating fluid (refer to Installation Section 3.2).

Close the release valve (37) by turning it clockwise and open the air vent by loosening the filler plug (35) a few turns. The shuttle valve (51) should be pulled outward from the pump body, the end of the knob approximately even with the edge of drip pan. In this position the high volume displacement mode is selected and the pump is self-priming. Operate the pump handle several times using full strokes, until you see fluid appear in the outer pump body outlet.

The cone seat (82) is located in the base of the outer-pump body outlet and serves as the sealing surface between the bottom of the piston and cylinder assembly and the pump body. Confirm the coned end of the seat is facing up and the cylindrical end of it is facing down. Thread the high pressure piston and cylinder assembly (79) or (67) into the outer body outlet as shown, using the wrenches provided.

Operate the pump handle a few more times until fluid is observed at the end of the offset pipe. Connect the gauge or other device to be tested to the offset pipe. For purposes of priming, the device must be designed to withstand the full operating pressure of 10,000 psi (70,000kPa). If a lower range device must be used, extreme care must be exercised to avoid overpressuring its pressure element. Seal the connection to the device by tightening nut adapter (62) and adapter (60) until the coned end of the pipe is forced into its inlet. If necessary, rotate the device for viewing by loosening nut adapter (62), set it to the proper position and retighten nut adapter.

Again, operate the pump handle a few more times. After a few strokes positive pressure will develop and the pump handle will begin to resist pumping action. Raise the pump handle to its uppermost travel position. Loosen the bleed screw (30) a half turn counter clockwise and slowly operate the pump handle through a downward stroke until fluid flows steadily from the bleed vent. Close the bleed screw just prior to completing the downward handle motion. Repeat this action until no air bubbles are observed in the fluid flow. (Note – the bleed screw must be closed when the handle is being raised). Push the shuttle valve

in towards the pump body and continue pumping to the desired test pressure. Open the release valve (37) to vent the pressure. To check operation pull the shuttle valve outward, close the release valve and operate the pump handle several times. When handle resistance is felt, push the shuttle valve inward and continue pumping within the range of the test device.

Entrapped air will prevent the pump from operating in the high pressure valve position or cause it to achieve only partial pressure. Repeat the above bleed procedure as necessary to assure all air is removed. Once air is removed the pump will continue to operate without further attention providing the reservoir level is maintained.

3.3.3 Weights

The weight set consists of a selection of various masses that will produce desired pressure increments when operated with the appropriate piston and cylinder assembly. Each weight is stamped with two pressure values. When applied to the high pressure piston and cylinder assembly the equivalent pressure value is indicated next to the letter "H". Conversely, when applied to the low pressure piston and cylinder assembly the equivalent pressure value is indicated next to the letter "L". The piston and piston platform also contribute to the total mass. Their equivalent pressure value is stamped on the top of the platform.

During normal operation, selected weights are added to the plate and piston assembly to equal the desired pressure value.

3.3.4 Levelness

The deadweight tester must be level to function properly. The unit may be leveled by placing a bubble type level on top of the piston plate and revolving it slowly. Shims may be used between drip pan and bench to level the piston plate. The unit is level when the position of the bubble does not change within the glass as it is rotated on top of the piston assembly.

3.3.5 Making the Test

Add weight to the piston plate to give desired calibrating pressure.

Pull the shuttle valve (51) outward from the body and close the pressure release valve (37). Operate the pump handle until the fluid pressure forces the piston to raise the weights. When pumping, the weights should be rotated slowly to decrease cylinder wall friction. If pump handle resistance is difficult and the weights have not risen, push the shuttle valve inward and continue pumping. With the shuttle valve pushed in, the fluid displacement of each stroke is reduced, thereby requiring less effort to continue pumping.

The piston assembly has a maximum lift of $\frac{3}{4}$ inch (1.9 cm). It is recommended that readings be taken at mid-point, or $\frac{3}{8}$ inch (1 cm) lift. Small adjustments to the piston lift can be made with the pump handle or the displacement valve (41).

Improper readings will result if the piston plate is so low that it rests on the bushing, or so high that the internal stop on the piston assembly is touching the underside of the bushing.

Spin the weights by hand and take readings only when the weights are spinning. Speed of rotation is unimportant, although a slow speed is more convenient and recommended.

To release pressure, turn valve (37) counterclockwise slowly.

3.3.6 To Dismantle

Figure 2-1 Ashcroft Portable Deadweight Tester 1305D

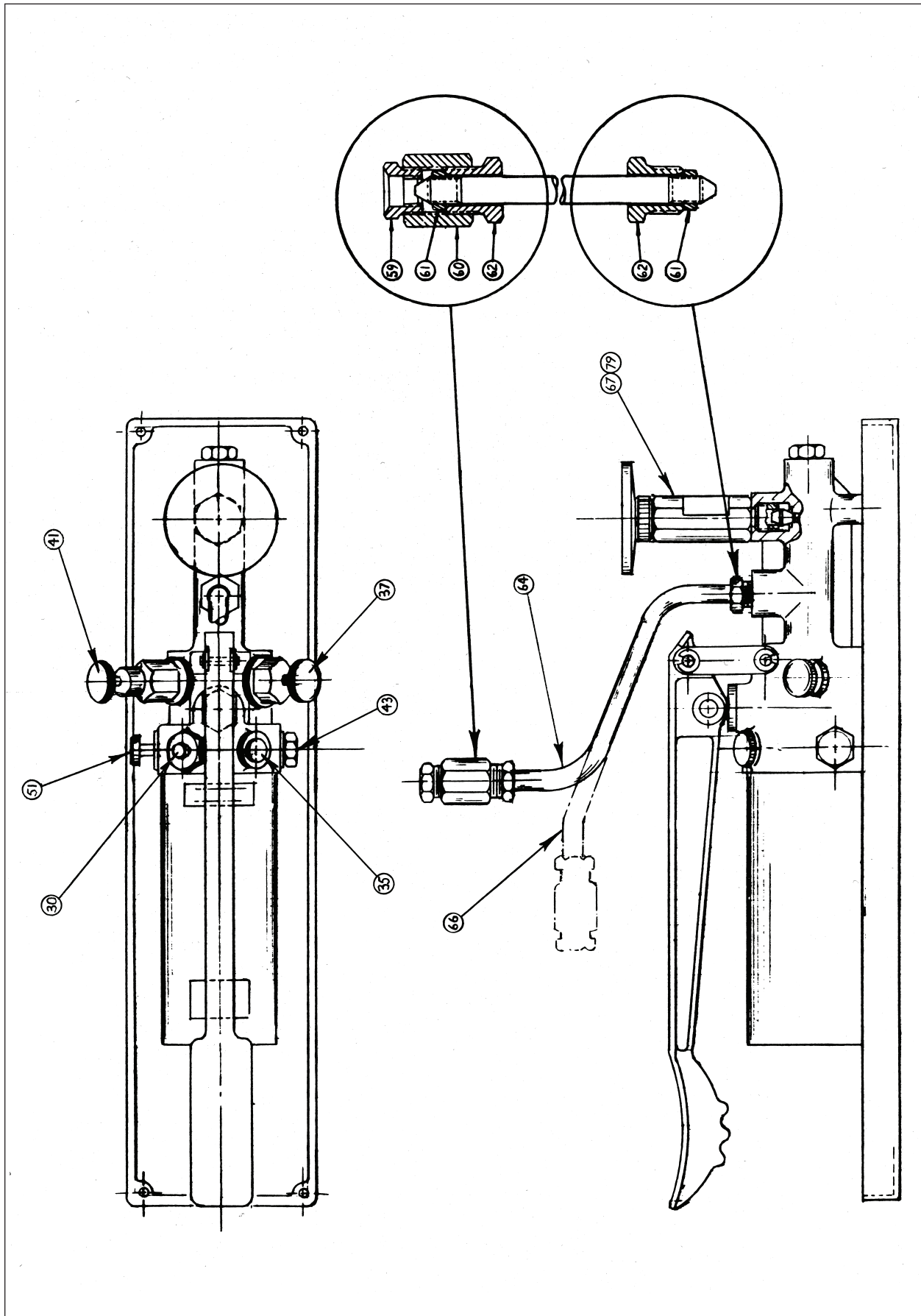

To replace the tester in its case, remove the gauge offset pipe assembly (64 or 66) and the piston and cylinder assembly (67 or 79). Install shipping plugs in body outlet holes. Screw in the displacement valve (41) until it stops. Close the vent plug (35). Open the release valve (37) approximately $\frac{1}{2}$ turn. Replace the tester in its case, reservoir last. Engage the spring clip catch.

3.3.7 General Precautions

It is important that the deadweight tester be connected to a leak tight system.

The deadweight tester should be set-up so that the axis of the located piston is vertical, the weights carefully centered on that axis, and the piston rotated during use. The purpose of the rotation is to spread the lubricant over the entire surface between piston and cylinder, so that there will be no metal-to-metal contact. If rotation is not maintained, the lubricant film will not cover the surface properly, and readings will be in error.

The high and low pressure piston assemblies have an internal overload stop, which prevents the piston and cylinder from being forced apart if weights are accidentally removed.

3.3.8 Operating Fluids

Standard Tester:

Any medium weight oil may be used (including automotive oils S.A.E. 10, 20 or 30) S.A.E. 20-W recommended.

Hydraulic Tester:

Any hydraulic fluid (silicate or phosphate base). Skydrol or Pydraul is suitable.

For normal operation, it is not necessary to change the weight of oil for various pressures. A lighter oil may be used where low pressures are being checked, and a heavier oil where higher pressures are being tested.

The reservoir can be refilled while the tester is operating under pressure.

3.3.9 Caution

Standard testers designed for oil service may not be used with water for oxygen service.

3.3.10

Hydraulic service testers should not be filled with water or any oil other than hydraulic fluid. Serious pump failure may occur due to O-ring damage.

3.4. Installation Type 1327

3.4.1 Set up Procedure (See Figures 2-2)

To remove the test pump from the case, release the spring clip, depressing the clip by hand, grasp the pump reservoir, and lift up the back end of the pump assembly.

Remove the two plastic shipping plugs from the outlet connections. Remove the threaded filler plug (35) from reservoir filling hole. Remove the offset pipe (64) or (66) from the carrying case and connect to the inner pump body outlet as shown in Figure 2-2. Remove the straight pipe extension (58), and assemble to outer vertical pump body outlet as shown in Figure 2-2.

3.4.2 Connecting The Gauge (See Figure 2-2)

Select a test gauge that is adequate for the pressure range desired. Assemble the test gauge to the straight pipe extension, using adapter nut (62), collar (61), adapter (60) and reducer bushing (59).

Seal the connection by tightening nut adapter (62) and adapter (60) until the coned end of the pipe is forced into the gauge socket. Rotate the gauge for viewing by loosening nut adapter (62), setting the gauge to the desired

position, and re-tightening nut adapter.

Repeat the above procedure to connect the gauge being tested to the offset pipe assembly (64) or (66).

3.4.3 Bench Space Required

Allow a space:

10 inch (2.5 cm) width

23 inch (5.8 cm) depth

22 inch (5.6 cm) height allows for testing gauges up to 8.5 inch (250 mm) size

3.4.4 Storage Space Required

10 $\frac{1}{2}$ inch (27 cm) width

22 $\frac{1}{2}$ in (57 cm) depth

10 inch (25 cm) height

Storage space dimensions are larger than actual size of test pump carrying case by approximately 0.5 inch (1.3 cm), in order to facilitate ease of handling in storage.

3.5 Operation 1327D

3.5.1 Test Gauge Selection

The portable test pump is used for calibrating instruments such as pressure gauges, pressure switches or other pressure devices rated up to 10,000 psi (70,000kPa).

First, select the proper test gauge, depending upon the pressure range desired. When priming the pump a test gauge rated to 10,000 psi (70,000kPa) should be used.

3.5.2 Priming The Pump

The offset pipe (64 or 66 Figure 2-2) and straight pipe extension (58) should already be secured in place and the reservoir should contain the operating fluid (refer to installation Section 3.4).

Close the release valve (37) by turning it clockwise and open the air vent by loosening the filler plug (35) a few turns. The shuttle valve (30) should be pulled outward from the pump body, the end of the knob approximately even with the edge of the drip pan. In this position the high volume displacement mode is selected and the pump is self-priming. Operate the pump handle several times using full strokes, until you see fluid appear at the top of the straight pipe extension. Connect the test gauge to it (refer to Installation Section 3.4 for proper gauge connection).

Operate the pump handle a few more times until fluid is observed at the end of the offset pipe. Connect the gauge or other device to be tested to the offset pipe. For purposes of priming, the device must be designed to withstand the full operating pressure of 10,000 psi (70,000kPa). If a lower range device must be used, extreme care must be exercised to avoid overpressuring its pressure element. Seal the connection to the device by tightening nut adapter (62) and adapter (60) until the coned end of the pipe is forced into its inlet. If necessary, rotate the device for viewing by loosening nut adapter (62), set it to the proper position and retighten nut adapter.

Again, operate the pump handle a few more times. After a few strokes positive pressure will develop and the pump handle will begin to resist pumping action. Raise the pump handle to its uppermost travel position. Loosen the bleed screw (51) a half turn counter clockwise and slowly operate the pump handle through a downward stroke until fluid flows steadily from the bleed vent. Close the bleed screw just prior to completing the downward handle motion. Repeat this action until no air bubbles are observed in the fluid flow. (Note – the bleed screw must be closed when the handle is being raised). Push the shuttle valve in towards the pump body and continue pumping to the desired test pressure. Open the release valve (37) to vent

the pressure. To check operation pull the shuttle valve outward, close the release valve and operate the pump handle several times. When handle resistance is felt, push the shuttle valve inward and continue pumping within the range of the test device.

Entrapped air will prevent the pump from operating in the high pressure valve position or cause it to achieve only partial pressure. Repeat the above bleeding procedure as necessary to assure all air is removed. Once air is removed the pump will continue to operate without further attention providing the reservoir level is maintained.

3.5.3 Making The Test

Turn displacement piston handle (41) to mid-position, so that it may be used for setting an exact pressure on the gauge. The displacement piston has internal stops which prevent unscrewing or accidental loss of pressure.

Clockwise rotation of displacement piston will produce an increase in pressure; counterclockwise will decrease pressure.

Prior to taking readings, both gauges should be finger-tapped lightly at the center of the gauge face, to eliminate any movement friction. Note the pressure readings on the test gauge and the gauge under test. If the pressure indicated on the gauge under test is not equal (within the tolerance of the gauge) to the pressures of the master test gauge, the gauge being tested requires calibration.

CAUTION:

Do not pump handle to pressures greater than the pressure range of the gauges connected to the test pump, as this may damage the gauges.

3.5.4 To Release Pressure

Open release valve slowly (37), until pressure returns to zero. Do not loosen any connections until pressure in the gauge tester has reached zero, as indicated on the test gauge.

If additional gauges are to be tested, close the release valve when the pressure reaches zero. This will prevent complete drainage of oil in the tester back to the reservoir.

Unseal the gauge that has been tested by unscrewing adapter nut (62) from connector (60) several turns. Unscrew the gauge from bushing (59) if used, or connector (60), and remove.

Remove the test gauge in the same manner as the gauge under test.

3.5.5 To Dismantle

To replace test pump in case, remove gauges and both tube assemblies. Put shipping plugs into pump and tighten. Close filler plug (35).

3.5.6 Operating Fluids

Standard Test Pump:

Any medium weight oil may be used (including automotive oils S.A.E 10, 20 or 30) S.A.E. 20-W recommended.

Hydraulic Test Pump:

Any hydraulic fluid (silicate or phosphate base). Skydrol or Pydraul is suitable.

Oxygen Test Pump:

Distilled or demineralized water with a compatible corrosion inhibitor added. A .1% solution of sodium dichromate is a suitable inhibitor.

For normal operation it is not necessary to change the weight of oil for various pressures. A lighter oil may be used where low pressures are being checked, a heavier oil where higher pressures are being tested.

The reservoir can be refilled while the test pump is operating under pressure.

3.5.7 Caution

Standard testers designed for oil service may not be used with water for oxygen service.

3.5.8

Hydraulic service testers should not be filled with water or any oil other than hydraulic fluid. Serious pump failure may occur due to O-ring damage.

4.0 FACTORS AFFECTING OPERATION OF DEADWEIGHT TESTERS

4.1 Deadweight Tester Accuracy

Excellent accuracy is possible using the deadweight tester through analysis and control of certain factors. If the tester's rated accuracy of 1/10th of 1% is adequate, then the nominal pressure (sum of the denominations of the weights loading the piston) may be assumed to be correct. The pressure normally developed is determined by this formula: Deadweight Tester Pressure =

$$\frac{\text{Mass of weights plus piston mass}}{\text{Effective area of piston and cylinder}}$$

$$P = \frac{(M-ph)}{A} \text{ gs}$$

P = pressure

M = mass of the load on the piston

A = effective area of the piston in sq. inches, or sq. cm

g/gs = ratio of the value (g) of gravity at the point of use to the standard value of gravity (gs)

P = density of liquid used in test

h = difference in level between gauge being tested, and the bottom of the piston

The deadweight tester is capable of measuring pressures to proper corrections after analyzing these factors.

4.2 Gravity, Calibrated Weights

Weights furnished are calibrated at standard gravity of 980.665 gals. If precise accuracy is required, the error introduced by change of weight due to change in gravity at the locality should be calculated and included in results.

The mechanism of an Ashcroft Pressure Gauge includes a Bourdon tube and geared movement, which is unaffected by variations in gravity. Conversely, the pressure developed by a deadweight tester is proportional to the value of gravity. Readings of this type pressure gauge will correspond to those of a deadweight tester when the tester is subjected to standard gravity (gs = 980.665 gals. in the International System). In southern sections of the United States, the value of gravity may be several thousandths less than the standard value, if the latitude (\emptyset) and the elevation above sea level (a) for an area are known, the approximate value of (g) in gals. may be calculated from this formula:

$$g = 980.632 - 2.586 \text{ COS } 2\emptyset + .003 \text{ COS } 4\emptyset - .000094a$$

\emptyset = Latitude (Degrees)

a = Elevation above sea level (ft)

4.3 Effective Measured Area: Chamber

The effective area of the deadweight tester may be determined by the average of the cross sectional area of the piston and the area of the cylinder bore. This effective area is affected somewhat by temperature, and by the elastic distortion of the piston and cylinder when pressure is being applied. The effective area of a stainless steel piston and cylinder increases approximately .068% with

a 50 degree F (28 degree C) change in temperature. The pressure will, therefore be less than indicated at high temperatures.

4.4 Mass, Height, and Buoyancy

The density of air at room temperature and sea level pressure is about 0.0012 grams/c.c., and the mass of the piston assembly and weights under these conditions will be reduced by about one part in 7,000 or .014%. When the submerged part of the piston has a uniform cross section, as with the 1305D Deadweight Tester, a buoyancy correction is not necessary. In other designs, the piston is sometimes enlarged to provide a stop for its upward motion or for increased strength. If these enlargements are submerged in liquid, a buoyancy correction is necessary.

4.5 Absence of Friction

By rotating the weights and piston, friction effects are greatly reduced.

4.6 Head of Transmitting Fluid

Oftentimes, the gauge being tested, or the point at which pressure is being measured, is not at the same level as the lower end of the piston. A correction, therefore, should be made for the pressure distance between these points; the height is considered positive when the gauge is above the piston. When oil is used in the gauge tester, the correction will be approximately 0.03 psi (.2 kPa) for each inch (2.54 cm) difference in level.

4.7 Method of Operation

It is important that the piston be kept floating in mid-position, either spinning or oscillating.

4.8 Levelness

The piston assembly should be vertical to within ± 1 degree. A 3 degree tilt to piston axis may cause a .13% of 1% error. The deadweight tester is manufactured and tested to 1/10th of 1% accuracy, to this degree of levelness. A tilt piston/cylinder axis causes excessive friction, due to side loading of the piston against the cylinder.

4.9 Cleanliness

The weights have been manufactured and tested to a precision of 0.05%. A buildup of dirt and grease may cause the weight value to exceed its original tolerance and produce erroneous pressure readings.

Periodically clean the weights to assure proper performance.

5.0 MAINTENANCE INSTRUCTION

5.1 General Maintenance

The Deadweight tester and test pump are designed to serve as precise pressure measuring standards. They are precision built units and should be cared for in the same manner as other sensitive laboratory equipment. General maintenance is limited to cleaning and replacement of O-ring packings, which can be done with tools supplied with the equipment and requires only limited disassembly of the gauge tester.

The piston supporting the weight platform has been manufactured to very close tolerances. It has an area accuracy of 1/20th of 1% and a weight accuracy of 1/20th of 1%. The deadweights have been certified traceable to N.I.S.T. with the accuracy of the finished weights better than 1/20th of 1%. To maintain deadweight tester accuracy, handle the weights with care and keep the piston and cylinder in clean condition.

The tester should be flushed with a solvent occasionally, preferably every six months, so that operating fluid is al-

ways clean. This will prolong component life, and provide protection against possible sticky action between the piston and cylinder. After cleaning, always lubricate parts before assembly.

If a deadweight tester is not used for long periods of time, or if a piston and cylinder assembly is being replaced, the piston should be removed from the cylinder and coated with the hydraulic fluid, so that it never operates in a dry state. When removing or replacing the piston, it should be rotated back and forth.

Should a piston or cylinder wear excessively, the tester will leak oil at a high rate, and will not be operable. A new piston and cylinder assembly should be installed.

Piston wear will result from improper or contaminated lubrication, excessive dirt, or from several years of continuous use.

5.2 Cleaning

Both the Tester and Test Pump should be cleaned thoroughly whenever the operating fluid is seriously contaminated with dirt, grit, or chemicals. A good practice is to clean the test unit prior to anticipated periods when the unit will not be in use.

5.3 To Disassemble for Cleaning

(See Figure 2-1, Figure 2-2 and Figure 5-1)

It is necessary to disassemble only those components which come in contact with the operating fluid. Complete disassembly is rarely necessary.

- a. Remove pipe extension assembly (58) or piston and cylinder assembly(67) and (79).
- b. Then remove lower or back connection pipe assembly (64, 66).

5.4 Removing Pump Handle and Piston

- a. Remove four retaining rings (8).
- b. Slide out two clevis pins (9).
- c. Remove clevis (10).
- d. Lift hand assembly (4) with piston pin (7) piston (20) O-ring packing (12, 19) and back-up ring (11) attached to it, out of piston sleeve (6).
- e. Remove back-up washers (18, 11) and O-ring packing (12, 19).
- f. Unscrew piston (20)
- g. Remove piston sleeve (6) and O-ring packing (45, 16) and back-up washers (46, 17)

5.5 Removing Reservoir and Fill Tube

- a. Unscrew filler plug (35) from reservoir.
- b. Remove gasket (36).
- c. Remove reservoir (5) by removing three screws (24).
- d. Twist reservoir to free O-ring packing (21) seat.
- e. Remove O-ring packing (21) from body (2).
- f. Remove fill tube assembly (23) and O-ring packing (27).
- g. Remove plug (22).

5.6 Removing Shuttle Valve, Shuttle Valve Plug and Check Valve

- a. Remove set screw (33) and spring (32).
- b. Slide shuttle valve piston (31) out of body (2). Operate back and forth as necessary to dislodge pin (31) engagement.
- c. Remove shuttle pin (31) by pushing it into the shuttle valve piston cavity using a plastic shaft less than $\frac{1}{8}$ inch (3mm) in diameter.
- d. Unscrew shuttle valve plug (43) and remove O-ring packing (27).
- e. Remove check valve spring (14) and check valve (44).
- f. Remove O-ring packing (15) from check valve (44).

5.7 Removing Bleeder Valve and Check Valve Assembly

- a. Unscrew bleeder valve (51)
- b. Unscrew bleed plug (50) and remove O-ring packing (27).
- c. Remove valve spacer (29) check valve spring (14) and check valve (44).
- d. Remove O-ring (15) from check valve (44).

5.8 Removing High Pressure Check Valve

- a. Unscrew plug (28) and remove O-ring packing (27).
- b. Unscrew adjusting screw (26).
- c. Remove guide rod (13), check valve spring (14), and check valve (44).
- d. Remove O-ring packing (15) from check valve (44).

5.9 Removing Release Valve

- a. Remove release valve assembly (37) and O-ring packing (27)
- b. Disassemble valve assembly by rotating handle counter-clockwise until valve stem is free from valve body.
- c. Remove O-ring packing from valve stem.
- d. Remove screw (38) and seal (39) by turning counter-clockwise.
- e. Remove O-ring packing (40).

5.10 Removing Displacement Valve

- a. Remove displacement valve assembly (41).
- b. Remove O-ring packing (27).
- c. Remove handle from stem by rotating handle counter-clockwise. This is not required for normal cleaning.
- d. Rotate the stem clockwise (using screwdriver in the slot at the top of the stem) until it is free from body.
- e. Remove nut back-up washers and ring packing from stem.

5.11 Stem Body from Drip Pan

- a. Take out three bolts (25). This is not required for normal cleaning.
- b. Remove body assembly (2) from drip pan (3). This is not required for normal cleaning.

5.12 Inspection

Visually inspect these parts for wear, damage, chips, cracks and stripped threads:

- Body Assembly Threads
- Piston
- Piston Sleeve (6)
- Displacement Stem and Mating Surface in Body
- Back-up Washers
- Moving O-ring Packings
- Dead Weights
- Piston and Cylinder Assembly – 1305D
- Test Gauges – 1327D

Back-up washers must fit snugly into piston sleeve and into displacement valve body. Then check static (non-moving) packing for pinch marks, tearing or extrusion. Check all valve seats for scratches and roughness.

Replace all worn or damaged parts. Replace all O-ring packings at each overhaul. Coat O-ring packings with suitable lubricant before replacing, to prevent sticking and tearing during assembly and tightening of connections.

5.13 Reassembly

When reassembling, use where possible the wrenches supplied with the equipment. These wrenches permit enough leverage to seal all connections. Excessive tightening of parts with tools other than those supplied may cause distortion and eventual failure of threaded portions of the tester body assembly casting. When replacing O-ring packings, coat them with suitable lubricant to pre-

vent sticking and tearing during assembly and tightening of connection.

5.14 To Reassemble

Body assembly on drip pans.

Replace body assembly (2) on drip pan (3) using bolts (25).

5.15 Replacing Displacement Valve

- a. Place O-ring packing between back-up washers.
- b. Attach back-up washers and O-ring packing to displacement valve stem with nut.
- c. Thread stem into body from the bottom – use screw driver in the slot at top of stem.
- d. Screw stem through body until the back-up washers, and O-ring packing are fully enclosed in the body.
CAUTION: Do not damage O-ring packing when threading stem through body.
- e. Screw handle onto stem.
- f. Replace displacement valve assembly (41) with O-ring packing (27) in body assembly (2).

5.16 Replacing Release Valve

- a. Place O-ring packing (40) in body casting (2) hole.
- b. Insert seat (39) into body casting hole.
- c. Thread & tighten screw (38) into body casting hole.
CAUTION: Be sure that stem of seat (39) fits into screw hole.
- d. Place O-ring packing on valve stem.
- e. Screw handle onto valve stem.
- f. Screw valve stem into body until end of stem does not extend beyond valve body.
CAUTION: Do not damage O-ring packing when threading valve stem through valve body.
- g. Replace O-ring packing (27).
- h. Replace release valve assembly (37) in body assembly (2).

5.17 Replacing High Pressure Check Valve

- a. Place O-ring packing (15) on check valve (44).
- b. Slide check valve (44), check valve spring (14), and guide rod (13) into body assembly (2).
- c. Replace adjusting screw (26) and screw it in until it stops.
- d. Then turn (26) back two complete revolutions.
- e. Replace plug (28) with O-ring packing (27) in body assembly (2).

5.18 Replacing Bleeder Valve and Check Valve Assembly

- a. Replace O-ring packing (15) on check valve (44).
- b. Slide check valve (44), check valve spring (14) and valve spacer (29) into body assembly (2).
- c. Replace bleed plug (50) with O-ring packing (27) into body assembly (2).

5.19 Replacing Shuttle Valve, Shuttle Valve Plug and Check Valve

- a. Insert shuttle valve piston (3) into body (2).
- b. Slide shuttle pin (31) into 1/8 inch (3mm) diameter opening adjacent to fill tube (23) port. Apply slight inserting pressure to shuttle pin (31) with plastic shaft and operating shuttle valve (30) to insure proper pin engagement.
- c. Replace spring (32) directly behind shuttle pin (31) and secure with set screw (33). Set screw must be recessed by .050 inch (12mm) minimum.
- d. Replace O-ring packing (15) on check valve (44).
- e. Slide check valve (44) and check valve spring (14) into body assembly (2).

5.20 Replacing Reservoir and Fill Tube

Figure 2-2 Ashcroft Portable Test Pump – Type 1327D

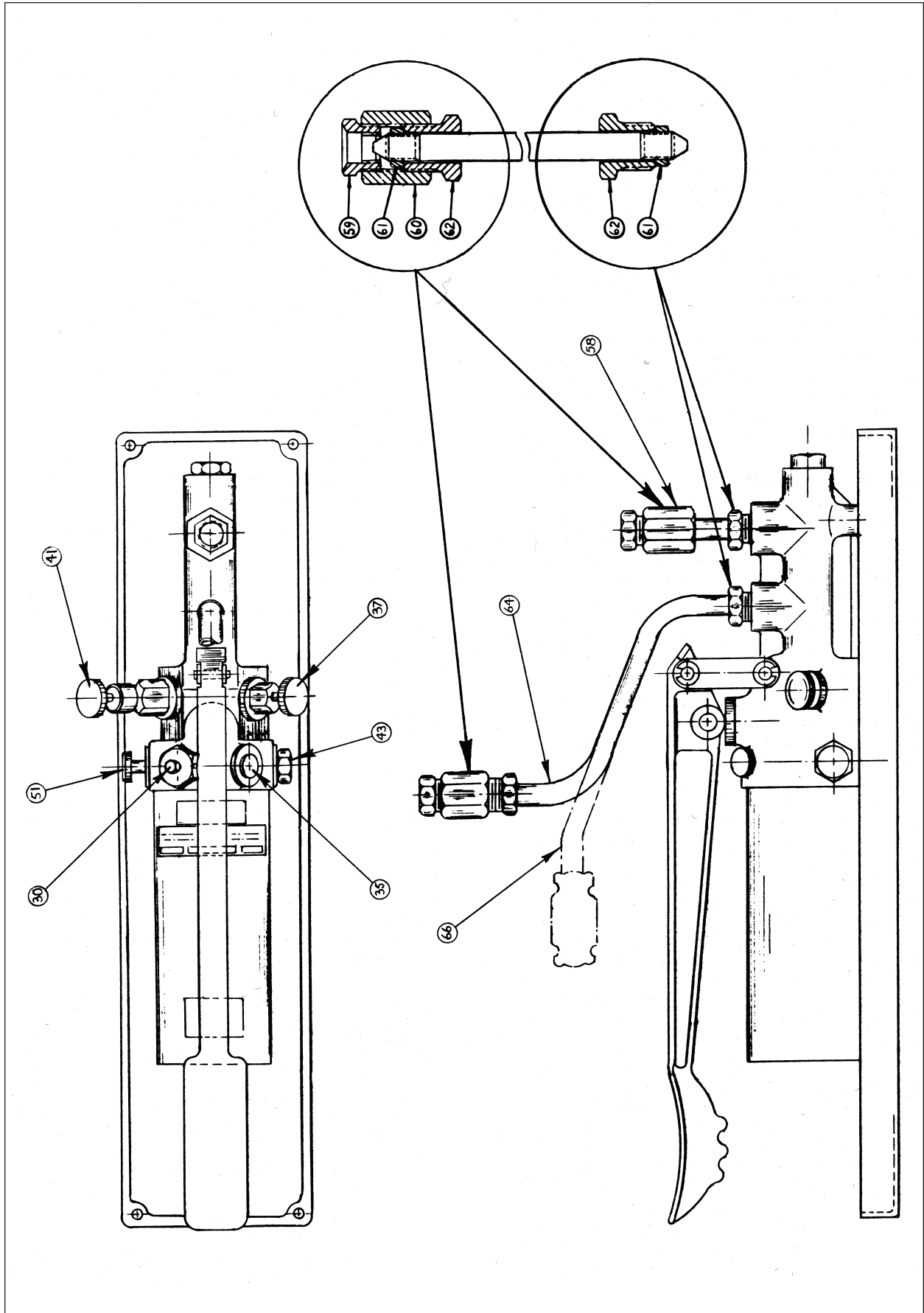

- a. Replace plug (22).
- b. Replace fill tube assembly (21) and O-ring packing (27).
- c. Replace O-ring packing (21) on body assembly (2).
- d. Replace reservoir (5) using three screws (24).
- e. Replace filler plug (35) and gasket (36) on body.

5.21 Replacing Pump Handle and Piston

- a. Replace piston sleeve (6) and O-ring packing (45, 16) and back-up washers (46, 17) in body assembly (2).
- b. Place O-ring packing (12, 19) between back-up washers (18, 11)
- c. Attach back-up washers (18,11) and O-ring packing (12, 19) to piston (20).
- d. Lubricate piston and sleeve.
- e. Attach assembled piston to handle assembly (4).
CAUTION: Do not damage O-ring packing (12, 19) when sliding assembled piston into piston sleeve (6).
- f. Attach clevis (10) to handle assembly and to body assembly (2), using clevis pins (9) and retaining rings (8).

5.22 Replacing Piston/Cylinder Assemblies

The piston/cylinder assembly for a deadweight tester should be replaced when excessive wear is detected on any component part. Worn piston assemblies are usually noted by:

- 1. Excessive leakage of operating fluid through piston assembly when under pressure.
- 2. Seizure of piston in cylinder.
- 3. Damaged piston plate, damaged cylinder threads, or damage to any component part that results in inferior performance, or malfunctioning of the unit.

The piston/cylinder assembly is available as a unit only. This assures the user of maximum accuracy in his Ashcroft Deadweight Tester and maintains certified traceability to the N.I.S.T.

6.0 WARRANTY – SHIPPING INSTRUCTIONS – HOW TO ORDER

6.1 Warranty and Limitation of Liability

All products and parts carry a warranty against defective material and workmanship for period of one (1) year from date of shipment.

A complete warranty and limitation of liability statement is made on the standard quotation form at the time of sale.

6.2 Shipping Instructions For Return To Factory

Pack securely to prevent possible damage in shipment.

SHIP TO: Ashcroft Inc.
250 East Main Street
Stratford, CT 06614
Phone: (203) 378-8281
Fax: (203) 385-0402
www.ashcroft.com
email: info@ashcroft.com

IMPORTANT – Obtain written authorization to return instruments that have been in contact with corrosive or hazardous materials such as mercury and radioactive solutions.

Please furnish the following information with return of instrument:

SHIPPING INSTRUCTIONS

Company Name _____

Phone Number _____

FAX Number _____

Person to Contact _____

Address _____

email Address _____

Model _____

Serial Number _____

Symptoms _____

5.4 Troubleshooting Chart

Symptom	Case	Corrective Action
Pressure does not build up when pumping handle.	Insufficient fluid level in reservoir.	Add fluid.
	Piston O-rings worn or ruptured.	Inspect O-rings and replace as necessary. If O-rings are new, verify their fluid compatibility.
	Bleed port check valve or shuttle check valve inoperative.	Inspect O-rings and replace as necessary.
	Fill tube assembly and filter plugged.	Remove and clean fill tube assembly. Refill reservoir with clean fluid.
	Shuttle valve pushed in for small fluid displacement when large fluid displacement is required.	Pull shuttle valve outward from body.
High pressure does not increase when pumping handle while shuttle valve is pushed in.	Air trapped in pump piston. Rapid pump handle strokes which lessen fluid flow through the pump piston.	Reprime pump. Operate pump handle with smooth moderate action.
Pressure builds up when pumping handle, but decreases when pumping is stopped.	Leakage at outlet or gauge connections(s). High pressure check valve O-ring worn or ruptured. Defective pressure release valve.	Inspect connections and tighten as necessary. Inspect O-ring and replace as necessary. Hand tighten release valve. Inspect release valve seating surfaces. Replace as necessary. Remove release valve seat and inspect O-ring underneath. Replace as necessary.

Symptom	Case	Corrective Action
Pump handle rises after pumping.	High pressure check valve O-ring worn or ruptured.	Inspect O-ring and replace as necessary.
Piston plate (with deadweights) drops rapidly.* Unable to hold constant pressure.	Worn piston and cylinder assembly.	Use a heavy oil temporarily. Replace piston & cylinder.
Stacked deadweights wobble when spinning piston plate.*	Damaged deadweights.	Check deadweights for visible damage (bends, dents, nicks, etc.) and alignment.
Piston plate assembly will not spin.*	Too heavy an oil grade being used.	Flush & fill unit with proper grade of oil (SAE 20 or SAE 10). Replace piston & cylinder assembly. Disassemble and flush complete test unit with kerosene or alcohol. Reassemble unit.

*These symptoms apply only to the 1305D Deadweight Testers.

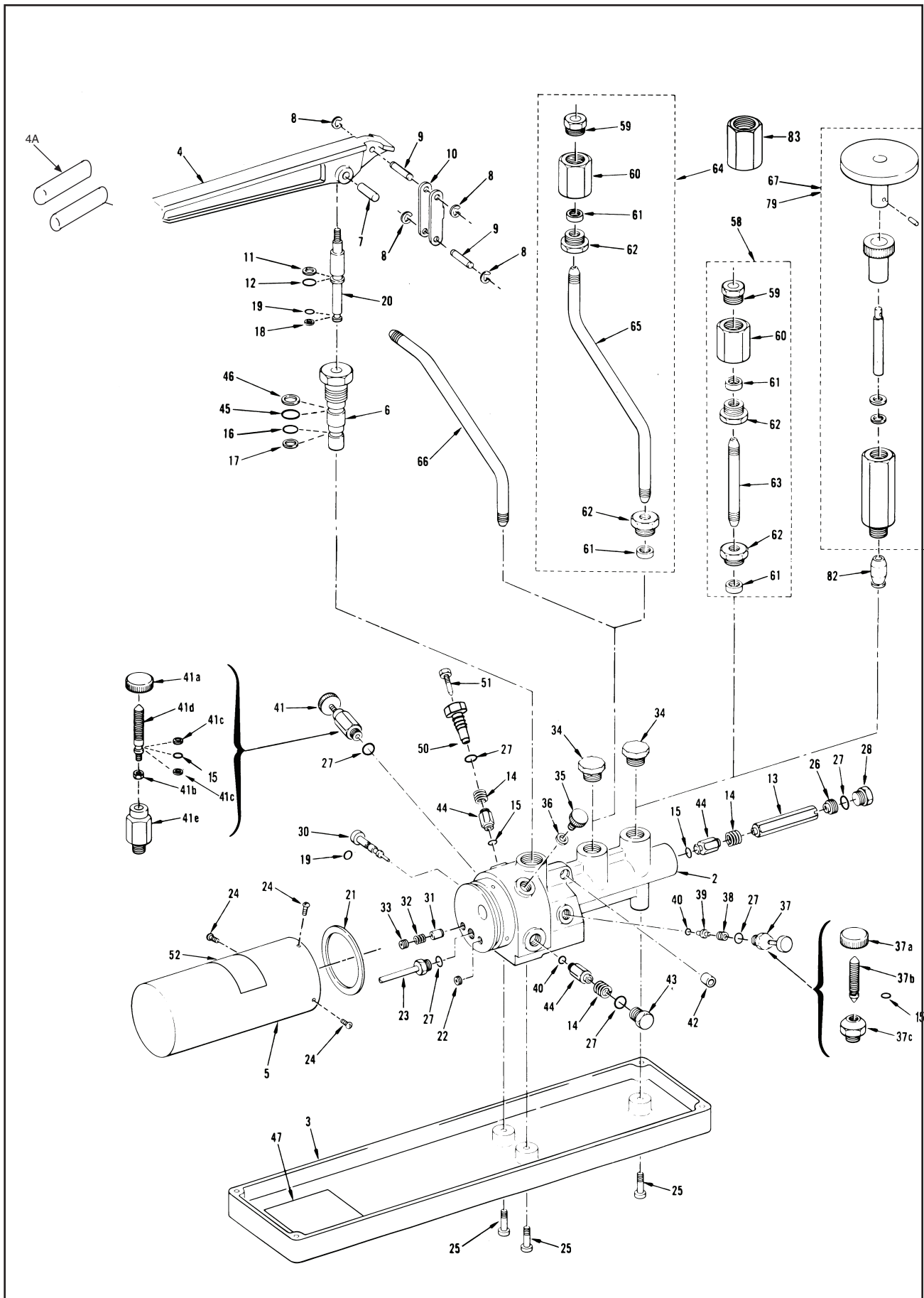

REPLACEMENT PARTS – D SERIES – BLUE COLOR

PORTABLE DEADWEIGHT TESTER – TYPE 1305D

PORTABLE TEST PUMP – TYPE 1327D

Item No.	Qty. Per Asmy.	Part No.	Description
2	1	603D001-01	Body Only, Pump
3	1	603D009-01	Drip Pan
4	1	603X010-01	Handle
4A	1	636X003-01	Grip
5	1	LF341A	Reservoir
6	1	610C001-01	Sleeve, Piston
7	1	LA810A	Pin, Piston
8	4	BA221L	Retaining Ring
9	2	LB810A	Pin, Clevis
10	1	LD278A	Clevis
11	1	607A002-02	Backup Ring
12	1	607A001-02	"O" Ring
13	1	LB802	Guide Rod
14	3	LA242	Spring, Valve
15	4	SSSS882	"O" Ring
16	1	607A001-03	"O" Ring
17	1	607A002-03	Backup Ring
18	1	607A002-01	Backup Ring
19	2	607A001-01	"O" Ring
20	1	614C001-01	Piston, Dual Diameter
21	1	BA122R	"O" Ring
22	1	604A003-01	Plug
23	1	615B001-01	Fill Tube Assembly
24	3	605A002-06	Screw, Round Head
25	3	SAFH37	Screw, Allen Socket Head
26	1	LK260A	Adjusting Screw
27	6	BA122V	"O" Ring
28	1	LK696A	Plug
29	1	—	Spacer, Valve, Use Item 50
30	1	614B002-01	Piston, Shuttle
31	1	609A001-01	Pin, Shuttle
32	1	612B001-01	Spring, Shuttle Pin
33	1	605A001-01	Set Screw
34	2	LP696	Plug, Shipping
35	1	604B002-01	Plug, Fill
36	1	607A003-01	Gasket, Fill Plug
37	1	LAH292C	Valve Assembly, Release
37a	1	328A105-01	Knob
37b	1	LD870B	Valve Stem
37c	1	LAH292A	Body, Release Valve
38	1	LD83A	ScREW, Seat
39	1	LD911A	Seat
40	2	BA122U	"O" Ring
41	1	LAG292C	Valve Assembly, Displacement
41a	1	328A105-02	Knob
41 b	1	LE83	Nut
41c	2	LB122	Backup Washer
41d	1	LB870A	Stem
41e	1	LAG292A	Body, Displacement Valve
42	1	LA521A	Sleeve
43	1	604B001-01	Plug, Shuttle Valve
44	3	609B003-01	Check Valve
45	1	BA122W	"O" Ring
46	1	607A002-04	Backup Ring
50	1	604B004-01	Plug, Bleed
51	1	609B004-01	Bleed Valve
52	1	LEE236	Nameplate
58	1	LK227	Pipe Extension Assembly

Item No.	Qty. Per Asmy.	Part No.	Description
59	2	LD227A	Bushing
60	2	LN141	Adapter
61	4	LD186	Collar
62	4	LD117	Nut, Adapter
63	1	LH227A	Extension Pipe
64	1	LJ227	Lower Connection Pipe Assembly
65	1	LF227A	Lower Connection Pipe
66	1	LG227A	Back Connection Pipe
67	—	—	Low Pressure Piston Assembly
	1	LM869	psig
79	—	—	High Pressure Piston Assembly
	1	LN869	psig
82	1	LF217	Disc Seat
83	1	LM141	Adapter
	1	617C002-01	"O" Ring Kit, Oil
	1	617A003-01	Overhaul Kit, Oil (see note 1)
	1	LH244A	Wrench (1 x 1 1/8)
	1	LH244	Wrench (7/8 x 1)
	1	LG244	Wrench (5/8)

*Piston and bushing can only be replaced as a complete assembly, the part number for this assembly is for:
1305D – part no. 617B001-01 List Price \$155.04
1305DH – part no. 617B001-02 List Price \$163.83

PARTS IN THE SECTION BELOW ARE USED IN HYDRAULIC SERVICE UNITS. THESE UNITS CAN BE RECOGNIZED BY THE INCLUSION OF THE LETTER "H" IN THE MODEL DESIGNATION.

12	1	607A004-02	"O" Ring
15	4	BA122H	"O" Ring
16	1	607A004-03	"O" Ring
19	2	607A004-01	"O" Ring
21	1	BA122E	"O" Ring
27	6	BA122D	"O" Ring
37	1	LAH292D	Valve Assembly, Release
40	2	BA122G	"O" Ring
41	1	LAG292D	Valve Assembly, Displacement
45	1	BA122F	"O" Ring
	1	LGG236A	Nameplate, Hydraulic
	1	617C002-02	"O" Ring Kit, Hydraulic
	1	617A003-02	Overhaul Kit, Hydraulic (see note 1)

1 Overhaul kit includes all O-rings required to overhaul pump as well as piston and bushing assembly.

PARTS IN THE SECTION BELOW ARE USED IN OXYGEN (DISTILLED WATER) SERVICE UNITS WHICH ARE IDENTIFIED BY THE INCLUSION OF THE LETTER "O" IN THE MODEL DESIGNATION.

47	1	LKK236	Oxygen Warning Label
58	1	LK227A	Pipe Extension Assembly
59	3	LD227B	Bushing
60	3	LN141A	Adapter
61	6	LD186A	Collar
62	6	LD117A	Nut, Adapter
64	1	LJ227A	Lower Connection, Pipe Assembly
83	1	LM141A	Adapter

AVAILABLE WEIGHTS & WEIGHT SETS

INDIVIDUAL WEIGHTS

Part Number	Units	Pressure Range	
		Low	High
LF199D	psig	1	5
LPF462	psig	2	10
LAZ199D	psig	5	25
LAZ199	psig	10	50
LAZ199A	psig	20	100
LAZ199B	psig	40	200
LAZ199C	psig	100	500

PSI WEIGHT SETS

Part Number	Weight Set with Carrying Case	Number of Weights by High Pressure Value				
		25 psi	50 psi	100 psi	200 psi	500 psi
LBH199C	1000 psi	1	3	2	3	–
LBH199B	2000 psi	1	3	2	3	2
LBH199A	3000 psi	1	3	2	3	4
LBH199*	5000 psi	1	3	2	3	8
LBH199D	5000 to 10000 psi	–	–	–	–	10

*For complete 10,000 psi weight set, order both part no. LBH199 and LBH199D.

Ashcroft Inc. 250 East Main Street
Stratford, CT 06614-5145 U.S.A.
Tel: 203-378-8281
email: info@ashcroft.com
www.ashcroft.com

All specifications are subject to change without notice.
All sales subject to standard terms and conditions.
©Ashcroft Inc. I&M002-10095_RevF_(250-1526)_09-20-22