

8008S Pressure Gauge

Features

- Meets EN837-1 and ASME B40.100 specifications
- Corrosion resistant all stainless steel case gauge
- R110 & NGV 3.1 Approvals
- FlutterGuard™ standard on dry gauges
- Custom dials available
- Accessory kits for easy panel mounting
- Designed to meet MSL Helium leak test of 1x10⁻⁶sc/c/s
- Optional solid front design (XS3)

Typical Uses

- Hydraulic systems
- Food and beverage
- Compressors and pumps
- Irrigation equipment
- Refrigerant applications
- Compressed and liquid natural gas applications
- Hydrogen cell, H2 gas applications and liquid natural gas applications



Specifications

Accuracy:	63 mm: ±1.6% of span per EN837-1 ±1% of span per EN837-1 (thru 10,000 psi) ±2-1-2% of span ASME B40.100 (thru 10,000 psi)
	100 mm: ±1% of span per EN837-1 (thru 10,000 psi)
Dial Sizes:	63 mm (2½"); 100 mm (4")
Ranges:	Vacuum, compound, 15 to 20,000 psi, bar, kPa, MPa, kg/cm ² , (available in single or dual scale)
Working Pressure:	Steady: 75% full-scale value Fluctuating: 80% full-scale value Short Time: full-scale value
Over Pressure/ Proof Pressure:	≤100 bar ranges: 125% of maximum scale value >100 to ≤600 bar ranges: 115% of maximum scale value >600 to ≤1400 bar ranges: 110% of maximum scale value
Process Connection Location:	63 mm: Lower, center back or lower back 100 mm: Lower, center back or lower back
Process Connection Sizes:	63 mm: ¼ NPT, ¼ NPT, G¼ B, ¼ BSPT, SAE-4 7/16-20, M14x1.5, #4JIC, ¼ Tube stub male, ⅜ Tube stub male, ½ Tube stub male 100 mm: ¼ NPT, ½ NPT, G¼ B, G½ B, M14x1.5, M20x1.5, ¼ BSPT, ½ BSPT, ¼ Tube stub male, ⅜ Tube stub male, ½ Tube stub male, ¼ High pressure female
Dial:	Black figures on white background (blue secondary scale for dual scale dials); aluminum
Pointer:	Black, aluminum
Movement:	316 Stainless steel
Dampening:	FlutterGuard™, Glycerin fill, Silicone fill
Temperature Effects:	±0.04% of span per °C change; reference temp. 20 °C ±0.4% of span per 18 °F change; reference temp. 68 °F

CSA/ANSI NGV 3.1:20 PXX

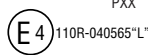

MH18518

Key Benefits

- Corrosion resistant
- Economical all stainless steel gauge
- Customizable for new applications
- Available in a variety of connections and ranges
- Enhanced safety with optional solid front design (XS3)

Wetted Components

Bourdon Tube	Process Connection	Restrictor
316 SS Laser Welded	316 SS Laser Welded	SS (0.013" orifice)

Non-Wetted Components

Case	Window	Ring
304 SS, open front (STD.)	Polycarbonate, glass, or safety glass	304 SS, crimped (STD.)
316 SS, open front (OPT.)	Polycarbonate, glass, or safety glass	316 SS, crimped (OPT.)
316 SS, solid front (XS3 OPT.)	Polycarbonate or safety glass	316 SS, crimped

Contact Us

1.800.328.8258

ashcroft.com

All specifications are subject to change without notice. All sales subject to standard terms and conditions.

Ashcroft®, FlutterGuard™ and Trust the Shield® are trademarks of Ashcroft Inc.



For more information, see [Ashcroft Brands & Trademarks](#)

©2026 Ashcroft Inc. 8008S_ds_RevL_13-April-2026

8008S Pressure Gauge

Specifications (continued)

Approvals: CE, RoHS (EU Directives 2011/65/EU and 2015/863); PED (2014/68/EU); CRN (15,000 & 20,000 psi not included); R110; NGV 3.1 IP66 rating; UL252A, NEMA 4X for water and dust ingress

 II 2G Ex h IIC T6... T1 Gb X
 II 2D Ex h IIC T85 °C... T450 °C Db X
 EU File No: 35422752
 TÜV NORD CERT (only with safety glass)

Min/Max Temperature Limits

Version	Ambient	Process	Storage
Dry with FlutterGuard™	-40 °F to 200 °F (-40 °C to 93 °C)	-40 °F to 250 °F (-40 °C to 121 °C)	-40 °F to 200 °F (-40 °C to 93 °C)
Glycerin Fill	20 °F to 158 °F (-7 °C to 70 °C)	-4 °F to 212 °F (-20 °C to 100 °C)	-40 °F to 158 °F (-40 °C to 70 °C)
Silicone Fill	-40 °F to 158 °F (-40 °C to 70 °C)	-40 °F to 212 °F (-40 °C to 100 °C)	-40 °F to 158 °F (-40 °C to 70 °C)
ATEX dry/silicone filled	-40 °F to 140 °F (-40 °C to 60 °C)	Check instruction manual	-40 °F to 140 °F (-40 °C to 60 °C)
ATEX Glycerine filled	-20 °F to 140 °F (-7 °C to 60 °C)	Check instruction manual	-4 °F to 140 °F (-20 °C to 60 °C)

8008S Pressure Gauge

Ordering Code	Example:	63	8008S	4	G	02	L	P	0	L	10BR	-XWP
Dial Size												
63 - 63 mm / 2½"		63										
10 - 100 mm / 4"												
Model												
8008S - Pressure gauge			8008S									
Case/Ring Material												
4 - 304 Stainless steel				4								
6 - 316 Stainless steel (standard on solid front XS3 gauges)												
Fill												
F - Dry with FlutterGuard™												
G - Glycerine filled					G							
S - Silicone filled												
N - Dry, silicone free												
T - Dry, with silicone free FlutterGuard™												
Process Connection Sizes (See Table on page 3 for more options)												
02 - ¼ NPT Male						02						
Process Connection Location												
B - Lower back												
C - Center-back												
D - 3 o'clock (right side)												
E - 9 o'clock (left side)												
L - Lower							L					
T - Top												
Window Material												
P - Polycarbonate								P				
R - Regular glass												
S - Safety glass												
Case Mounting												
0 - Stem mounting									0			
1 - U-clamp (center back only; connection mounted; not available on solid front XS3 gauges)												
2 - Front flange (lower back and centerback only)												
3 - Rear flange (not available on solid front XS3 gauges)												
4 - Front flange and U-clamp (center back only; connection mounted; not available on solid front XS3 gauges)												
5 - Trim ring and U-clamp (center back only; connection mounted; not available on solid front XS3 gauges)												
6 - U-clamp (lower back and center back only; case mounted; not available on solid front XS3 gauges)												
8 - Front flange and u-clamp (lower back and center back only; case mounted; not available on solid front XS3 gauges)												
9 - Trim ring and u-clamp (lower back and centerback only; case mounted; not available on solid front XS3 gauges)												
Accuracy												
J - ±1% of span (not available in 15,000 psi or 20,000 psi)												
L - ±1.6% of span										L		
M - ±2-1-2% of span (not available in 15,000 psi or 20,000 psi)												
Ranges (coding example only, see Table 1 for all standard ranges)												
10BR - Black primary and secondary dial scales on white background											10BR	
100#/BR - 100# black primary inner scale/ Bar minor blue outer scale (number value is dominant scale)												
BR/100# - Bar minor blue inner scale/ 100# black primary outer scale (number value is dominant scale)												
Options (If choosing an option(s) must include an "-X") (See Table on page 3 for more options)												
WP - Omit restrictor												WP

8008S Pressure Gauge

Process Connection Size Table

Connection Code	Process Connection
01	1/8 NPT Male (63 mm only)
02	1/4 NPT Male
04	1/2 NPT Male (100 mm only)
09	1/4 High pressure, female (recommended for 20,000 psi, 100 mm only)
13	G1/4 B Male
15	G1/2 B Male (100 mm only)
16	M20x1.5 (100 mm only)
41	M14x1.5 (63 mm only)
EJ	#4JIC (63 mm only)
KA	1/4 BSPT
KD	1/2 BSPT (100 mm only)
JP	1/4" Tube stub, male (not available on 15,000 psi or 20,000 psi)
JR	3/8" Tube stub, male (not available on 15,000 psi or 20,000 psi)
JS	1/2" Tube stub, male (not available on 15,000 psi or 20,000 psi)
AW	SAE-4, J1453-1 3/16-18 (not available on 20,000 psi) (63 mm only)
RW	SAE-4 7/16-20 (63 mm only) (not available on 15,000 psi or 20,000 psi)
25	1/4 NPT Female (63 mm only) (5,000 psi Limit)
LX	3/16 HP Male tube, long (Cone & Thread) (100 mm only) (Lower mount only)
RX	3/16 HP Male tube, short (Cone & Thread) (100 mm only) (Lower mount only)

Options (If choosing an option(s) must include an "X")

AR - Adjustable red indicator and min/max drag pointer (63 mm dry gauge only)

BM - Black primary and secondary dial scales on white background

CR - Custom individual carton label information

RM - Black primary and red secondary dial scales on white background

WP - Omit restrictor

ZO - Bulk packaging

ZP - Customer part number and description on Ashcroft label

ZQ - Customer part number only (no Ashcroft®)

ZW - Customer part number and gauge description on label (no Ashcroft identification)

B1 - Black protective boot (63 mm only, lower connect or center back connect only)

S2 - Safety pattern gauge without baffle wall; designed by S2 per EN837-1 (only available on 63 mm gauge having a polycarbonate window)

S3 - Safety pattern gauge with baffle wall, designed by S3 per EN837-1 (only available in 63 mm, 316 SS case/ring, lower or lower back connection, polycarbonate or safety glass window)

99 - Serial number on dial

ML - Mass spectrometer leak test

R5 - Ammonia refrigerant dial (30IMV&150#, 30IMV&300#)

8N- NGV 3.1 Approval on dial

8R- R110 Approval on dial

D3 - DuraVis™ retroreflective dial

C4 - [Traceable calibration certificate](#)

NH - Metal tag

RU - UL252A Approval on dial

AX - ATEX approval (Safety glass is required)

Contact Us

 1.800.328.8258

 ashcroft.com

All specifications are subject to change without notice. All sales subject to standard terms and conditions.

Ashcroft®, FlutterGuard™ and Trust the Shield® are trademarks of Ashcroft Inc.

For more information, see [Ashcroft Brands & Trademarks](#)

©2026 Ashcroft Inc. 8008S_ds_RevL_13-April-2026

8008S Pressure Gauge

Table 1 - Commercial Gauge Ranges

psi	bar	kPa	Mpa	kg/cm ²	NOTES
30IMV	-1BR	-100KP	-.1MP	-1KSC	
-	-1&.6BR	-100&60KP	-.1&.06MP	-1&.6KSC	
V&15#	-	-	-	-	
-	-1&1.5BR	-100&150KP	-.1&.15MP	-1&1.5KSC	
V&30#	-	-	-	-	
-	-1&3BR	-100&300KP	-.1&.3MP	-1&3KSC	
V&60#	-	-	-	-	
-	-1&5BR	-100&500KP	-.1&.5MP	-1&5KSC	
V&100#	-	-	-	-	
V&150#	-	-	-	-	
V&300#	-	-	-	-	
-	-1&9BR	-100&900KP	-.1&.9MP	-1&9KSC	
15#	1BR	100KP	.1MP	1KSC	
20#	-	-	-	-	
-	1.6BR	160KP	.16MP	1.6KSC	
30#	-	-	-	-	
-	2.5BR	250KP	.25MP	2.5KSC	
60#	4BR	400KP	.4MP	4KSC	
-	6BR	600KP	.6MP	6KSC	
100#	-	-	-	-	
120#	-	-	-	-	
-	10BR	1000KP	1MP	10KSC	
160#	-	-	-	-	
200#	-	-	-	-	
-	16BR	1600KP	1.6MP	16KSC	
300#	-	-	-	-	
-	25BR	2500KP	2.5MP	25KSC	
400#	-	-	-	-	
500#	-	-	-	-	
600#	40BR	4000KP	4MP	40KSC	
-	60BR	6000KP	6MP	60KSC	
1000#	-	-	-	-	
1500#	100BR	10000KP	10MP	100KSC	
2000#	-	-	-	-	
-	160BR	16000KP	16MP	160KSC	
3000#	-	-	-	-	
-	250BR	25000KP	25MP	250KSC	
4000#	-	-	-	-	
5000#	-	-	-	-	
6000#	400BR	40000KP	40MP	400KSC	
7500#	-	-	-	-	
-	600BR	60000KP	60MP	600KSC	
10000#	-	-	-	-	
15000#	1000BR	100000KP	100MP	1000KSC	Only available with ±1.6% of span accuracy.
20000#	-	-	-	-	Only available with ±1.6% of span accuracy. This range is not CRN registered.

8008S Pressure Gauge

Dimensions in [] are millimeters

For reference only, consult Ashcroft for specific dimensional drawings

100 mm lower connect		
Connection Code	Process Connection	Height
02	¼ NPT	5.51 [139.8]
04	½ NPT	5.55 [141.1]
09	¼ HP Female	5.55 [141.1]
13	G¼ B	5.42 [137.7]
15	G½ B	5.67 [144.0]
16	M20x1.5	5.67 [144.0]
JP	¼ Tube	5.53 [140.5]
JR	¾ BSPT	5.66 [143.8]
JS	½ Tube	5.79 [147.1]
KA	¼ BSPT or R ¼	5.41 [137.5]
KD	½ BSPT or R ½	5.55 [141.1]

100 mm lower connect - rear flange		
Connection Code	Process Connection	Height
02	¼ NPT	5.51 [139.8]
04	½ NPT	5.55 [141.1]
09	¼ HP Female	5.55 [141.1]
13	G¼ B	5.42 [137.7]
15	G½ B	5.67 [144.0]
16	M20x1.5	5.67 [144.0]
JP	¼ Tube	5.53 [140.5]
JR	¾ BSPT	5.66 [143.8]
JS	½ Tube	5.79 [147.1]
KA	¼ BSPT or R ¼	5.41 [137.5]
KD	½ BSPT or R ½	5.55 [141.1]

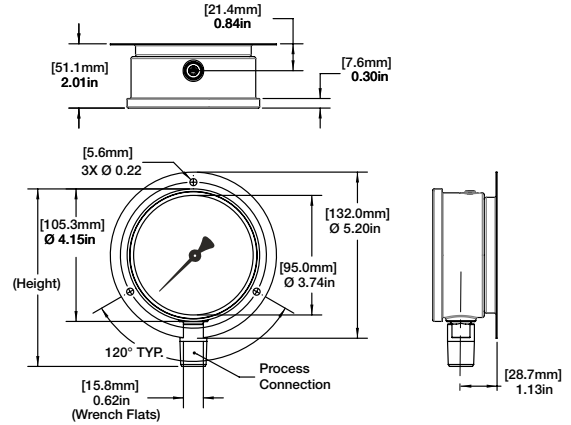
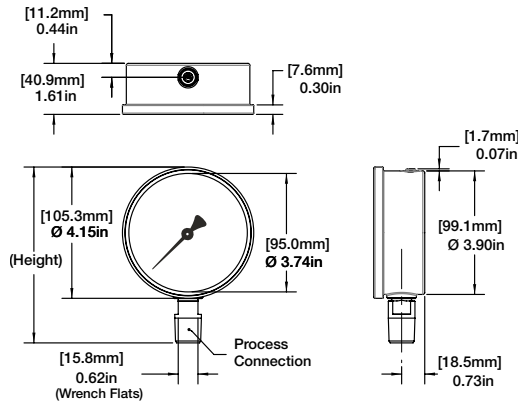

100 mm lower back connect		
Connection Code	Process Connection	Depth
02	¼ NPT	3.13 [79.5]
04	½ NPT	3.13 [79.5]
09	¼ HP Female	3.13 [79.5]
13	G¼ B	3.13 [79.5]
15	G½ B	3.26 [82.8]
16	M20x1.5	3.26 [82.8]
JP	¼ Tube	3.13 [79.5]
JR	¾ BSPT	3.25 [82.6]
JS	½ Tube	3.38 [85.9]
KA	¼ BSPT or R ¼	3.13 [79.5]
KD	½ BSPT or R ½	3.14 [79.8]

100 mm lower back connect - case mounted U-clamp		
Connection Code	Process Connection	Depth
02	¼ NPT	3.13 [79.5]
04	½ NPT	3.13 [79.5]
09	¼ HP Female	3.13 [79.5]
13	G¼ B	3.13 [79.5]
15	G½ B	3.26 [82.8]
16	M20x1.5	3.26 [82.8]
JP	¼ Tube	3.13 [79.5]
JR	¾ BSPT	3.25 [82.6]
JS	½ Tube	3.38 [85.9]
KA	¼ BSPT or R ¼	3.13 [79.5]
KD	½ BSPT or R ½	3.14 [79.8]

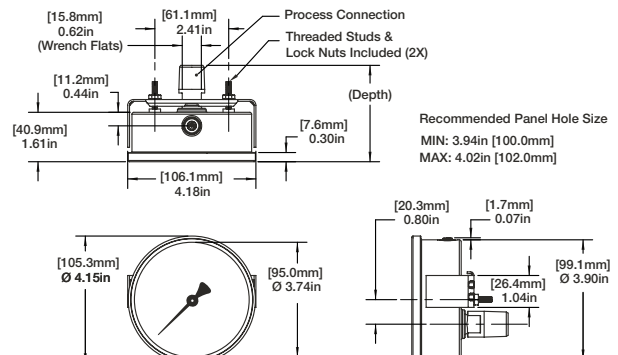
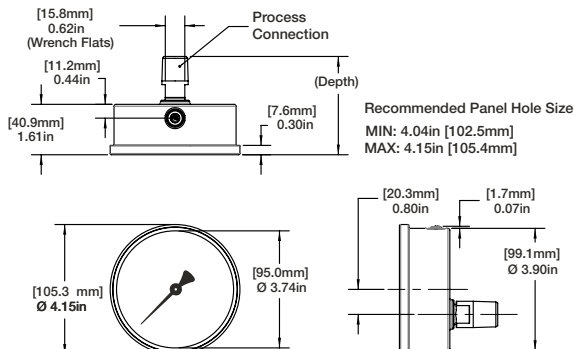

8008S Pressure Gauge

Dimensions in [] are millimeters

For reference only, consult Ashcroft for specific dimensional drawings

100 mm lower back connect - front flange		
Connection Code	Process Connection	Depth
02	¼ NPT	3.13 [79.5]
04	½ NPT	3.13 [79.5]
09	¼ HP Female	3.13 [79.5]
13	G¼ B	3.13 [79.5]
15	G½ B	3.26 [82.8]
16	M20x1.5	3.26 [82.8]
JP	¼ Tube	3.13 [79.5]
JR	¾ BSPT	3.25 [82.6]
JS	½ Tube	3.38 [85.9]
KA	¼ BSPT or R ¼	3.13 [79.5]
KD	½ BSPT or R ½	3.14 [79.8]

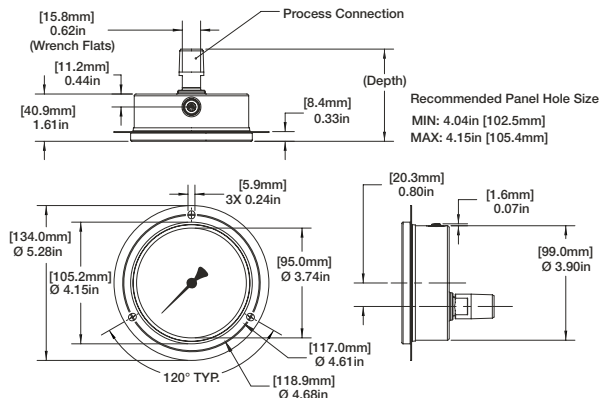

100 mm lower back connect - front flange, case mounted U-clamp		
Connection Code	Process Connection	Depth
02	¼ NPT	3.13 [79.5]
04	½ NPT	3.13 [79.5]
09	¼ HP Female	3.13 [79.5]
13	G¼ B	3.13 [79.5]
15	G½ B	3.26 [82.8]
16	M20x1.5	3.26 [82.8]
JP	¼ Tube	3.13 [79.5]
JR	¾ BSPT	3.25 [82.6]
JS	½ Tube	3.38 [85.9]
KA	¼ BSPT or R ¼	3.13 [79.5]
KD	½ BSPT or R ½	3.14 [79.8]

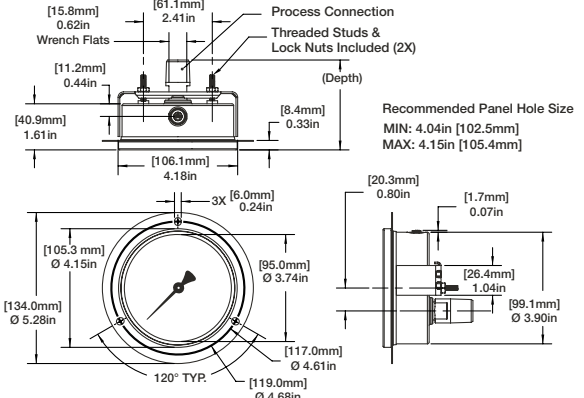

100 mm lower back connect - trim ring, case mounted U-clamp		
Connection Code	Process Connection	Depth
02	¼ NPT	3.13 [79.5]
04	½ NPT	3.13 [79.5]
09	¼ HP Female	3.13 [79.5]
13	G¼ B	3.13 [79.5]
15	G½ B	3.26 [82.8]
16	M20x1.5	3.26 [82.8]
JP	¼ Tube	3.13 [79.5]
JR	¾ BSPT	3.25 [82.6]
JS	½ Tube	3.38 [85.9]
KA	¼ BSPT or R ¼	3.13 [79.5]
KD	½ BSPT or R ½	3.14 [79.8]

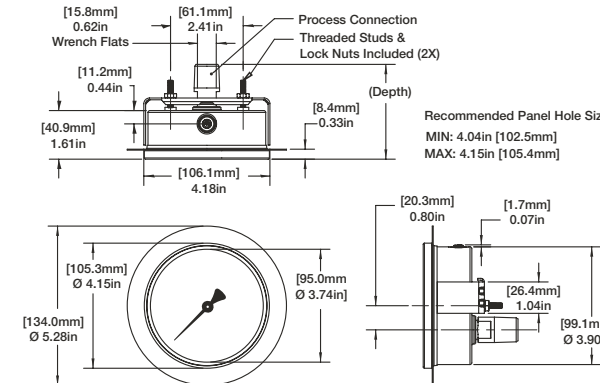

100 mm lower back connect - rear flange		
Connection Code	Process Connection	Depth
02	¼ NPT	3.13 [79.5]
04	½ NPT	3.13 [79.5]
09	¼ HP Female	3.13 [79.5]
13	G¼ B	3.13 [79.5]
15	G½ B	3.26 [82.8]
16	M20x1.5	3.26 [82.8]
JP	¼ Tube	3.13 [79.5]
JR	¾ BSPT	3.25 [82.6]
JS	½ Tube	3.38 [85.9]
KA	¼ BSPT or R ¼	3.13 [79.5]
KD	½ BSPT or R ½	3.14 [79.8]

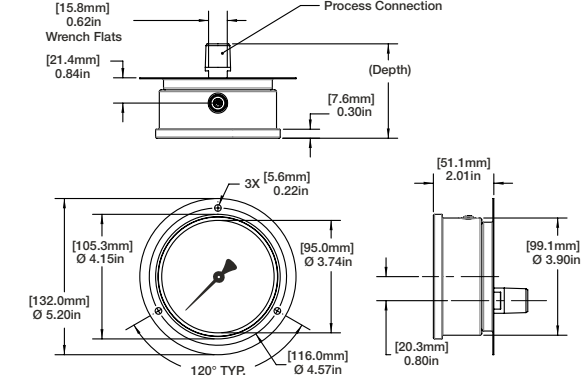

8008S Pressure Gauge

Dimensions in [] are millimeters

For reference only, consult Ashcroft for specific dimensional drawings

100 mm center back connect

Connection Code	Process Connection	Depth
02	¼ NPT	3.13 [79.5]
04	½ NPT	3.14 [79.8]
09	¼ HP Female	3.14 [79.8]
13	G¼ B	3.13 [79.5]
15	G½ B	3.26 [82.8]
16	M20x1.5	3.26 [82.8]
JP	¼ Tube	3.13 [79.5]
JR	⅜ BSPT	3.25 [82.6]
JS	½ Tube	3.38 [85.9]
KA	¼ BSPT or R ¼	3.13 [79.5]

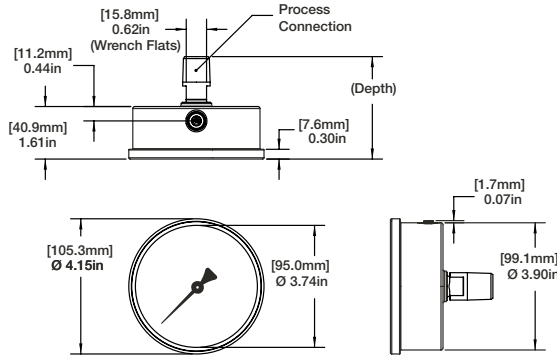

100 mm center back connect - connection mounted U-clamp

Connection Code	Process Connection	Depth
02	¼ NPT	3.13 [79.5]
04	½ NPT	3.13 [79.5]
09	¼ HP Female	3.13 [79.5]
13	G¼ B	3.13 [79.5]
15	G½ B	3.26 [82.8]
16	M20x1.5	3.26 [82.8]
JP	¼ Tube	3.13 [79.5]
JR	⅜ BSPT	3.25 [82.6]
JS	½ Tube	3.38 [85.9]
KA	¼ BSPT or R ¼	3.13 [79.5]

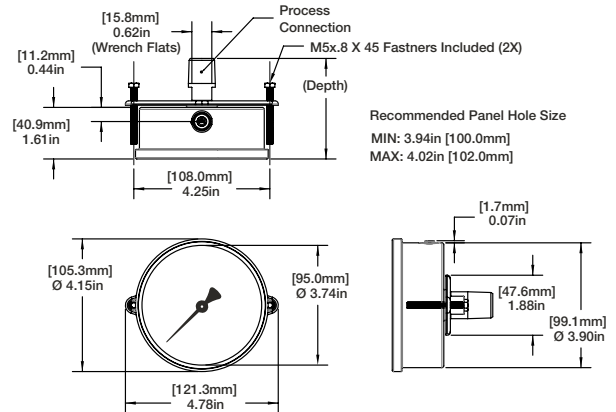

100 mm center back connect - case mounted U-clamp

Connection Code	Process Connection	Depth
02	¼ NPT	3.13 [79.5]
04	½ NPT	3.14 [79.8]
09	¼ HP Female	3.14 [79.8]
13	G¼ B	3.13 [79.5]
15	G½ B	3.26 [82.8]
16	M20x1.5	3.26 [82.8]
JP	¼ Tube	3.13 [79.5]
JR	⅜ BSPT	3.25 [82.6]
JS	½ Tube	3.38 [85.9]
KA	¼ BSPT or R ¼	3.13 [79.5]

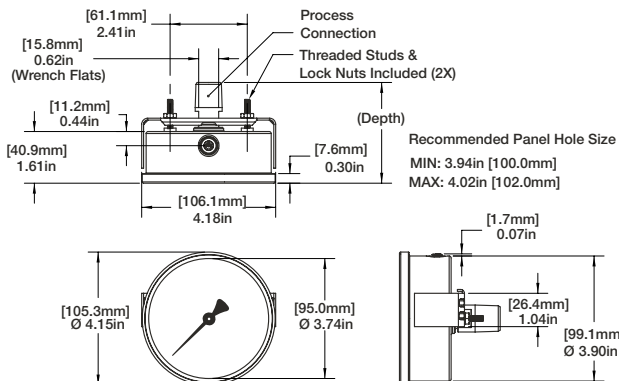

100 mm center back connect - front flange

Connection Code	Process Connection	Depth
02	¼ NPT	3.13 [79.5]
04	½ NPT	3.13 [79.5]
09	¼ HP Female	3.13 [79.5]
13	G¼ B	3.13 [79.5]
15	G½ B	3.26 [82.8]
16	M20x1.5	3.26 [82.8]
JP	¼ Tube	3.13 [79.5]
JR	⅜ BSPT	3.25 [82.6]
JS	½ Tube	3.38 [85.9]
KA	¼ BSPT or R ¼	3.13 [79.5]

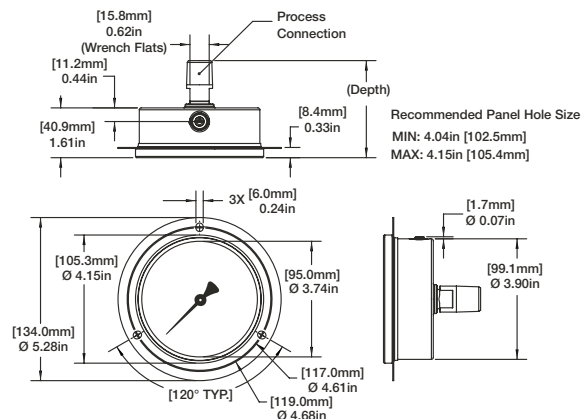

8008S Pressure Gauge

Dimensions in [] are millimeters

For reference only, consult Ashcroft for specific dimensional drawings

100 mm center back connect - front flange, conn. mounted U-clamp

Connection Code	Process Connection	Depth
02	¼ NPT	3.13 [79.5]
04	½ NPT	3.13 [79.5]
09	¼ HP Female	3.13 [79.5]
13	G¼ B	3.13 [79.5]
15	G½ B	3.26 [82.8]
16	M20x1.5	3.26 [82.8]
JP	¼ Tube	3.13 [79.5]
JR	¾ BSPT	3.25 [82.6]
JS	½ Tube	3.38 [85.9]
KA	¼ BSPT or R ¼	3.13 [79.9]

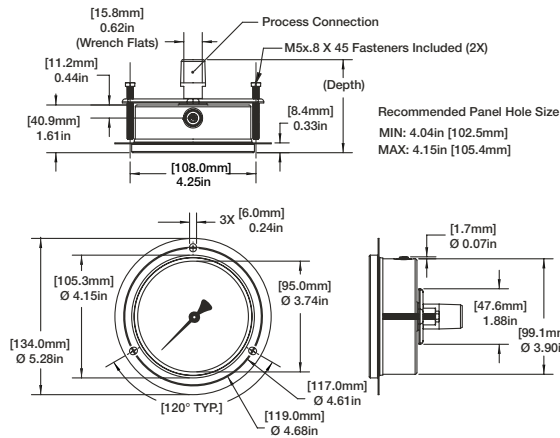

100 mm center back connect - front flange, case mounted U-clamp

Connection Code	Process Connection	Depth
02	¼ NPT	3.13 [79.5]
04	½ NPT	3.13 [79.5]
09	¼ HP Female	3.13 [79.5]
13	G¼ B	3.13 [79.5]
15	G½ B	3.26 [82.8]
16	M20x1.5	3.26 [82.8]
JP	¼ Tube	3.13 [79.5]
JR	¾ BSPT	3.25 [82.6]
JS	½ Tube	3.38 [85.9]
KA	¼ BSPT or R ¼	3.13 [79.5]

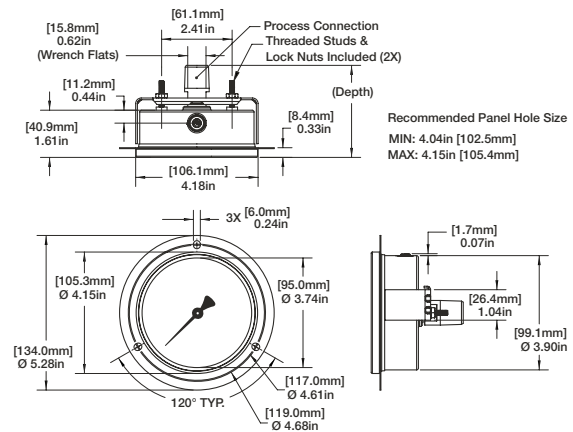

100 mm center back connect - trim ring, connection mounted U-clamp

Connection Code	Process Connection	Depth
02	¼ NPT	3.13 [79.5]
04	½ NPT	3.13 [79.5]
09	¼ HP Female	3.13 [79.5]
13	G¼ B	3.13 [79.5]
15	G½ B	3.26 [82.8]
16	M20x1.5	3.26 [82.8]
JP	¼ Tube	3.13 [79.5]
JR	¾ BSPT	3.25 [82.6]
JS	½ Tube	3.38 [85.9]
KA	¼ BSPT or R ¼	3.13 [79.5]

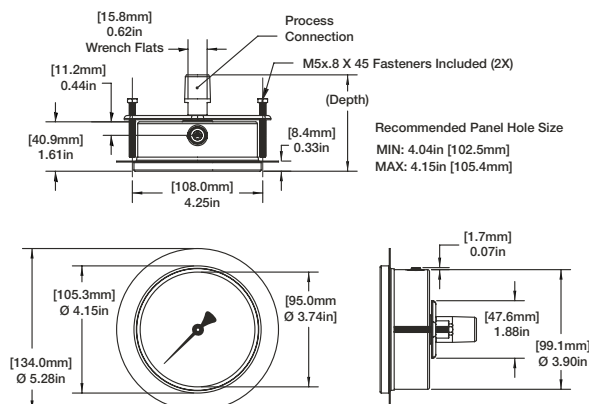

100 mm center back connect - trim ring, case mounted U-clamp

Connection Code	Process Connection	Depth
02	¼ NPT	3.13 [79.5]
04	½ NPT	3.13 [79.5]
09	¼ HP Female	3.13 [79.5]
13	G¼ B	3.13 [79.5]
15	G½ B	3.26 [82.8]
16	M20x1.5	3.26 [82.8]
JP	¼ Tube	3.13 [79.5]
JR	¾ BSPT	3.25 [82.6]
JS	½ Tube	3.38 [85.9]
KA	¼ BSPT or R ¼	3.13 [79.5]

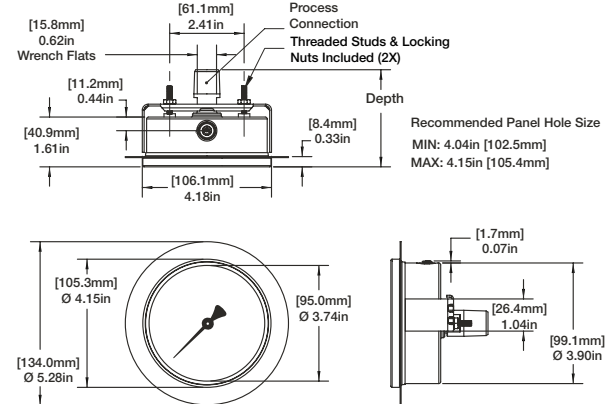

Contact Us

1.800.328.8258
ashcroft.com

All specifications are subject to change without notice. All sales subject to standard terms and conditions.

Ashcroft®, FlutterGuard™ and Trust the Shield® are trademarks of Ashcroft Inc.

For more information, see [Ashcroft Brands & Trademarks](#)

©2026 Ashcroft Inc. 8008S_ds_RevL_13-April-2026

8008S Pressure Gauge

Dimensions in [] are millimeters

For reference only, consult Ashcroft for specific dimensional drawings

100 mm center back connect - rear flange

Connection Code	Process Connection	Depth
02	¼ NPT	3.13 [79.5]
04	½ NPT	3.13 [79.5]
09	¼ HP Female	3.13 [79.5]
13	G¼ B	3.13 [79.5]
15	G½ B	3.26 [82.8]
16	M20x1.5	3.26 [82.8]
JP	¼ Tube	3.13 [79.5]
JR	¾ BSPT	3.25 [82.6]
JS	½ Tube	3.38 [85.9]
KA	¼ BSPT or R ¼	3.13 [79.5]

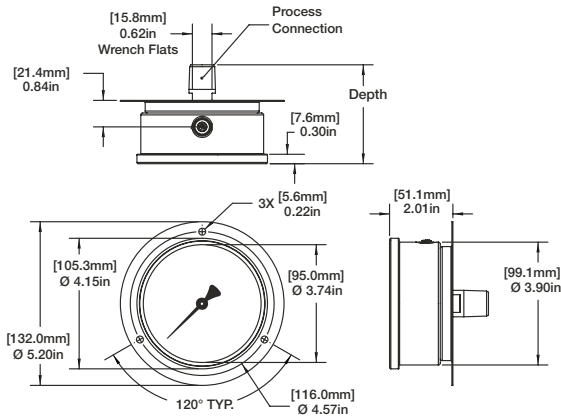

63 mm lower connect

Connection Code	Process Connection	Height
01	¼ NPT	3.68 [93.5]
02	¼ NPT	3.81 [96.8]
13	G¼ B	3.81 [96.8]
41	M14x1.5	3.85 [97.8]
EJ	JIC #4	3.75 [95.3]
JP	¼ Tube	3.92 [99.6]
JR	¾ Tube	4.05 [102.9]
JS	½ Tube	4.18 [106.2]
KA	¼ BSPT	3.73 [94.7]
RW	SAE ¼-20	3.93 [99.6]

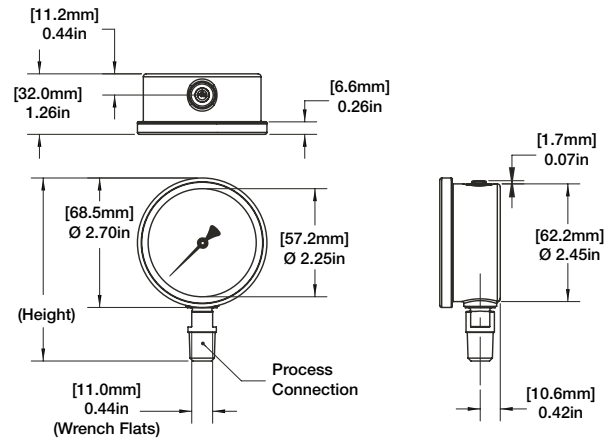

63 mm lower connect - rear flange

Connection Code	Process Connection	Height
01	¼ NPT	3.68 [93.5]
02	¼ NPT	3.81 [96.8]
13	G¼ B	3.81 [96.8]
41	M14x1.5	3.85 [97.8]
EJ	JIC #4	3.75 [95.3]
JP	¼ Tube	3.92 [99.6]
JR	¾ Tube	4.05 [102.9]
JS	½ Tube	4.18 [106.2]
KA	¼ BSPT	3.73 [94.7]
RW	SAE ¼-20	3.93 [99.6]

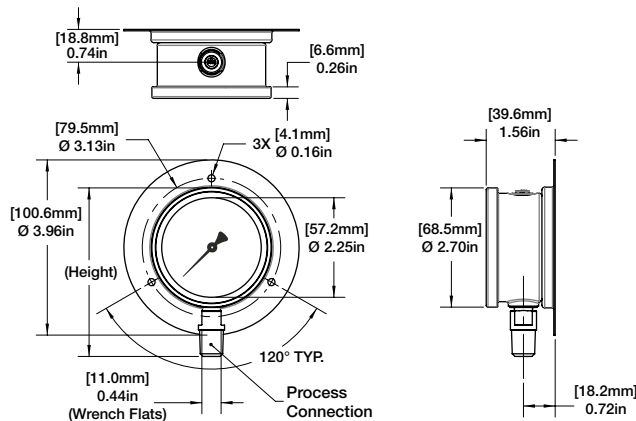

63 mm lower connect - protective boot

Connection Code	Process Connection	Height
01	¼ NPT	3.75 [95.3]
02	¼ NPT	3.88 [98.6]
13	G¼ B	3.88 [98.6]
41	M14x1.5	3.92 [99.6]
EJ	JIC #4	3.82 [97.0]
JP	¼ Tube	3.99 [101.3]
JR	¾ Tube	4.12 [104.6]
JS	½ Tube	4.25 [108.0]
KA	¼ BSPT	3.80 [96.5]
RW	SAE ¼-20	3.99 [101.3]

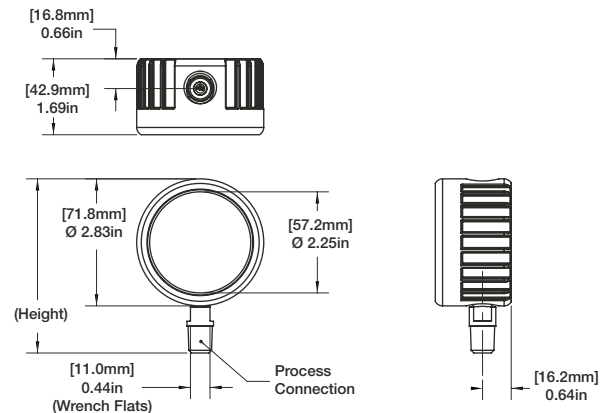

Contact Us

1.800.328.8258
ashcroft.com

All specifications are subject to change without notice. All sales subject to standard terms and conditions.

Ashcroft®, FlutterGuard™ and Trust the Shield® are trademarks of Ashcroft Inc.

For more information, see [Ashcroft Brands & Trademarks](#)

©2026 Ashcroft Inc. 8008S_ds_RevL_13-April-2026

8008S Pressure Gauge

Dimensions in [] are millimeters

For reference only, consult Ashcroft for specific dimensional drawings

63 mm lower back connect

Connection Code	Process Connection	Depth
01	¼ NPT	2.36 [60.0]
02	¼ NPT	2.50 [63.4]
13	G¼ B	2.49 [63.3]
41	M14x1.5	2.53 [64.3]
EJ	JIC #4	2.44 [62.0]
JP	¼ Tube	2.60 [66.1]
JR	¾ Tube	2.73 [69.4]
JS	½ Tube	2.86 [72.7]
KA	¼ BSPT	2.42 [61.4]
RW	SAE ⅞-20	2.60 [66.1]

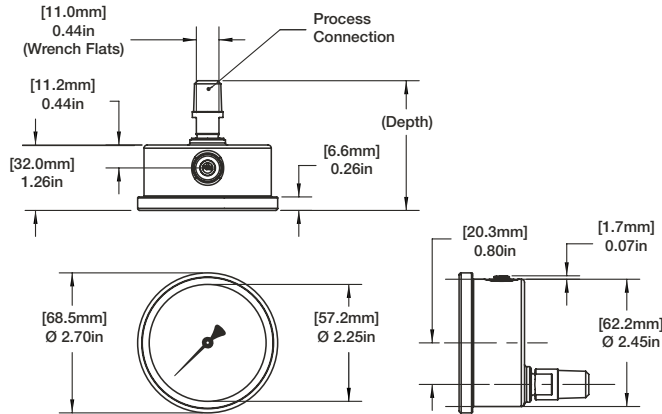

63 mm lower back connect - case mounted U-clamp

Connection Code	Process Connection	Depth
01	¼ NPT	2.36 [60.0]
02	¼ NPT	2.50 [63.4]
13	G¼ B	2.49 [63.3]
41	M14x1.5	2.53 [64.3]
EJ	JIC #4	2.44 [62.0]
JP	¼ Tube	2.60 [66.1]
JR	¾ Tube	2.73 [69.4]
JS	½ Tube	2.86 [72.7]
KA	¼ BSPT	2.42 [61.4]
RW	SAE ⅞-20	2.60 [66.1]

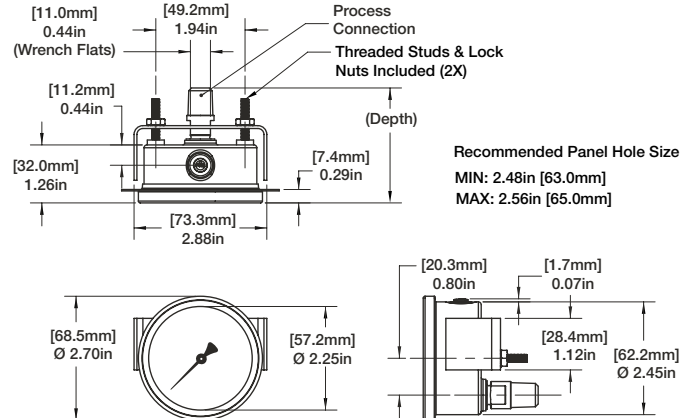

63 mm lower back connect - front flange

Connection Code	Process Connection	Depth
01	¼ NPT	2.36 [60.0]
02	¼ NPT	2.50 [63.4]
13	G¼ B	2.49 [63.3]
41	M14x1.5	2.53 [64.3]
EJ	JIC #4	2.44 [62.0]
JP	¼ Tube	2.60 [66.1]
JR	¾ Tube	2.73 [69.4]
JS	½ Tube	2.86 [72.7]
KA	¼ BSPT	2.42 [61.4]
RW	SAE ⅞-20	2.60 [66.1]

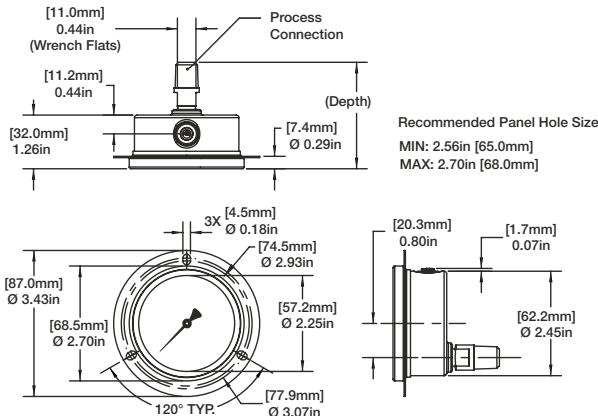

63 mm lower back connect - front flange, case mounted U-clamp

Connection Code	Process Connection	Depth
01	¼ NPT	2.36 [60.0]
02	¼ NPT	2.50 [63.4]
13	G¼ B	2.49 [63.3]
41	M14x1.5	2.53 [64.3]
EJ	JIC #4	2.44 [62.0]
JP	¼ Tube	2.60 [66.1]
JR	¾ Tube	2.73 [69.4]
JS	½ Tube	2.86 [72.7]
KA	¼ BSPT	2.42 [61.4]
RW	SAE ⅞-20	2.60 [66.1]

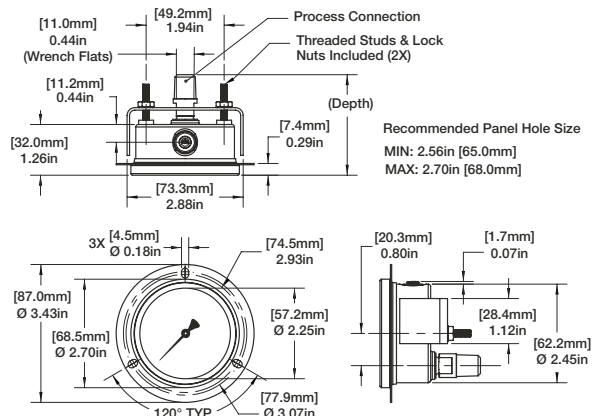

8008S Pressure Gauge

Dimensions in [] are millimeters

For reference only, consult Ashcroft for specific dimensional drawings

63 mm lower back connect - trim ring, case mounted U-clamp

Connection Code	Process Connection	Depth
01	1/8 NPT	2.36 [60.0]
02	1/4 NPT	2.50 [63.4]
13	G1/4 B	2.49 [63.3]
41	M14x1.5	2.53 [64.3]
EJ	JIC #4	2.44 [62.0]
JP	1/4 Tube	2.60 [66.1]
JR	3/8 Tube	2.73 [69.4]
JS	1/2 Tube	2.86 [72.7]
KA	1/4 BSPT	2.42 [61.4]
RW	SAE 7/16-20	2.60 [66.1]

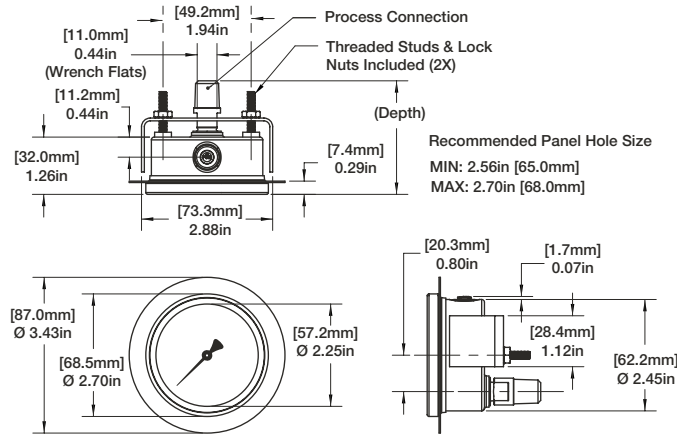

63 mm lower back connect - rear flange

Connection Code	Process Connection	Depth
01	1/8 NPT	2.36 [60.0]
02	1/4 NPT	2.50 [63.4]
13	G1/4 B	2.49 [63.3]
41	M14x1.5	2.53 [64.3]
EJ	JIC #4	2.44 [62.0]
JP	1/4 Tube	2.60 [66.1]
JR	3/8 Tube	2.73 [69.4]
JS	1/2 Tube	2.86 [72.7]
KA	1/4 BSPT	2.42 [61.4]
RW	SAE 7/16-20	2.60 [66.1]

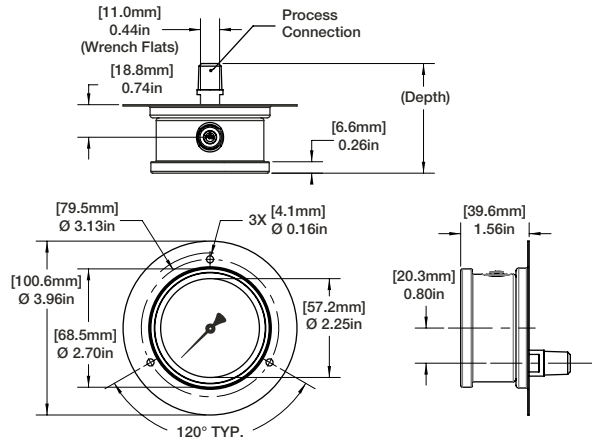

63 mm center back connect

Connection Code	Process Connection	Depth
01	1/8 NPT	2.36 [60.0]
02	1/4 NPT	2.50 [63.4]
13	G1/4 B	2.49 [63.3]
41	M14x1.5	2.53 [64.3]
EJ	JIC #4	2.44 [62.0]
JP	1/4 Tube	2.60 [66.1]
JR	3/8 Tube	2.73 [69.4]
JS	1/2 Tube	2.86 [72.7]
KA	1/4 BSPT	2.42 [61.4]
RW	SAE 7/16-20	2.60 [66.1]

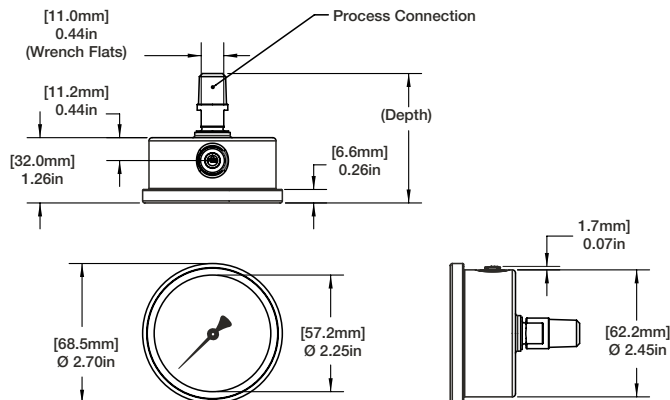

63 mm center back connect - connection mounted U-clamp

Connection Code	Process Connection	Depth
01	1/8 NPT	2.36 [60.0]
02	1/4 NPT	2.50 [63.4]
13	G1/4 B	2.49 [63.3]
41	M14x1.5	2.53 [64.3]
EJ	JIC #4	2.44 [62.0]
JP	1/4 Tube	2.60 [66.1]
JR	3/8 Tube	2.73 [69.4]
JS	1/2 Tube	2.86 [72.7]
KA	1/4 BSPT	2.42 [61.4]
RW	SAE 7/16-20	2.60 [66.1]

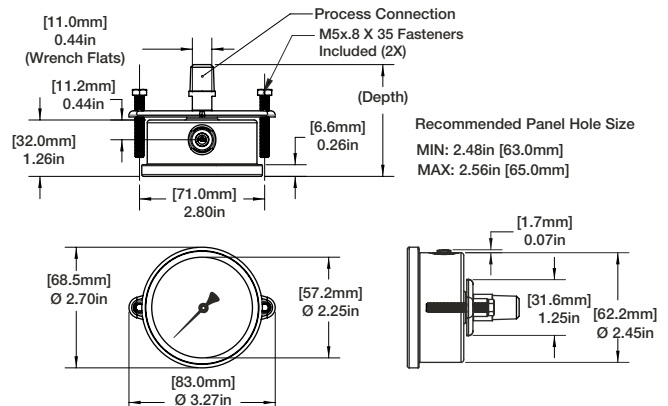

Contact Us

1.800.328.8258
ashcroft.com

All specifications are subject to change without notice. All sales subject to standard terms and conditions. Ashcroft®, FlutterGuard™ and Trust the Shield® are trademarks of Ashcroft Inc. For more information, see [Ashcroft Brands & Trademarks](#)
©2026 Ashcroft Inc. 8008S_ds_RevL_13-April-2026

8008S Pressure Gauge

Dimensions in [] are millimeters

For reference only, consult Ashcroft for specific dimensional drawings

63 mm center back connect - case mounted U-clamp

Connection Code	Process Connection	Depth
01	¼ NPT	2.36 [60.0]
02	¼ NPT	2.50 [63.4]
13	G¼ B	2.49 [63.3]
41	M14x1.5	2.53 [64.3]
EJ	JIC #4	2.44 [62.0]
JP	¼ Tube	2.60 [66.1]
JR	¾ Tube	2.73 [69.4]
JS	½ Tube	2.86 [72.7]
KA	¼ BSPT	2.42 [61.4]
RW	SAE ⅜-20	2.60 [66.1]

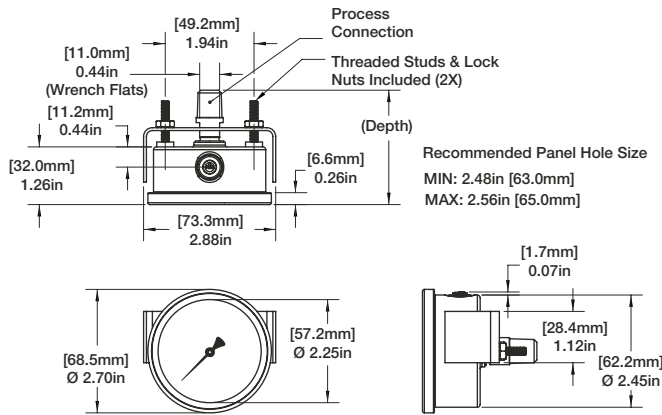

63 mm center back connect - front flange

Connection Code	Process Connection	Depth
01	¼ NPT	2.36 [60.0]
02	¼ NPT	2.50 [63.4]
13	G¼ B	2.49 [63.3]
41	M14x1.5	2.53 [64.3]
EJ	JIC #4	2.44 [62.0]
JP	¼ Tube	2.60 [66.1]
JR	¾ Tube	2.73 [69.4]
JS	½ Tube	2.86 [72.7]
KA	¼ BSPT	2.42 [61.4]
RW	SAE ⅜-20	2.60 [66.1]

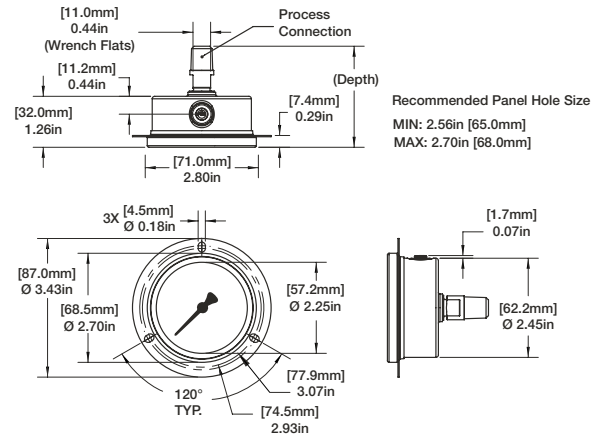

63 mm center back connect - front flange, connection mounted U-clamp

Connection Code	Process Connection	Depth
01	¼ NPT	2.36 [60.0]
02	¼ NPT	2.50 [63.4]
13	G¼ B	2.49 [63.3]
41	M14x1.5	2.53 [64.3]
EJ	JIC #4	2.44 [62.0]
JP	¼ Tube	2.60 [66.1]
JR	¾ Tube	2.73 [69.4]
JS	½ Tube	2.86 [72.7]
KA	¼ BSPT	2.42 [61.4]
RW	SAE ⅜-20	2.60 [66.1]

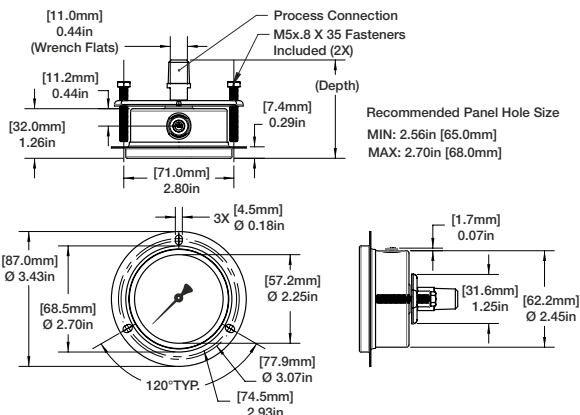

63 mm center back connect - front flange, case mounted U-clamp

Connection Code	Process Connection	Depth
01	¼ NPT	2.36 [60.0]
02	¼ NPT	2.50 [63.4]
13	G¼ B	2.49 [63.3]
41	M14x1.5	2.53 [64.3]
EJ	JIC #4	2.44 [62.0]
JP	¼ Tube	2.60 [66.1]
JR	¾ Tube	2.73 [69.4]
JS	½ Tube	2.86 [72.7]
KA	¼ BSPT	2.42 [61.4]
RW	SAE ⅜-20	2.60 [66.1]

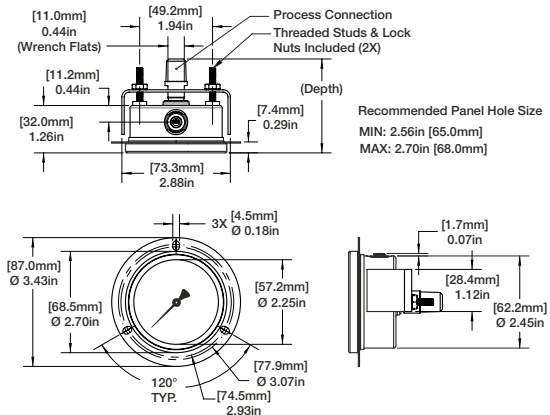

8008S Pressure Gauge

Dimensions in [] are millimeters

For reference only, consult Ashcroft for specific dimensional drawings

63 mm center back connect - trim ring, connection mounted U-clamp

Connection Code	Process Connection	Depth
01	¼ NPT	2.36 [60.0]
02	¼ NPT	2.50 [63.4]
13	G¼ B	2.49 [63.3]
41	M14x1.5	2.53 [64.3]
EJ	JIC #4	2.44 [62.0]
JP	¼ Tube	2.60 [66.1]
JR	¾ Tube	2.73 [69.4]
JS	½ Tube	2.86 [72.7]
KA	¼ BSPT	2.42 [61.4]
RW	SAE ⅜-20	2.60 [66.1]

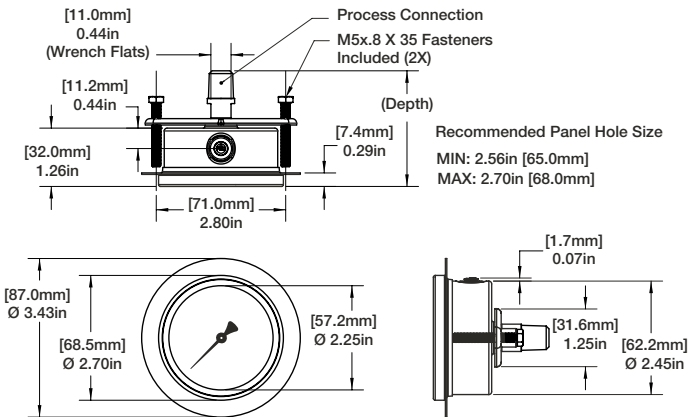

63 mm center back connect - trim ring, case mounted U-clamp

Connection Code	Process Connection	Depth
01	¼ NPT	2.36 [60.0]
02	¼ NPT	2.50 [63.4]
13	G¼ B	2.49 [63.3]
41	M14x1.5	2.53 [64.3]
EJ	JIC #4	2.44 [62.0]
JP	¼ Tube	2.60 [66.1]
JR	¾ Tube	2.73 [69.4]
JS	½ Tube	2.86 [72.7]
KA	¼ BSPT	2.42 [61.4]
RW	SAE ⅜-20	2.60 [66.1]

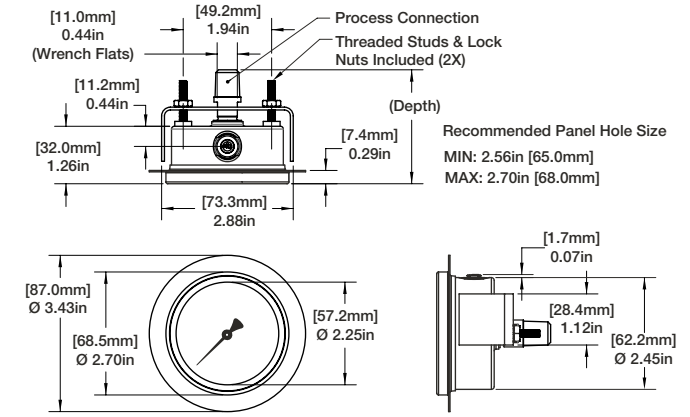

63 mm center back connect - rear flange

Connection Code	Process Connection	Depth
01	¼ NPT	2.36 [60.0]
02	¼ NPT	2.50 [63.4]
13	G¼ B	2.49 [63.3]
41	M14x1.5	2.53 [64.3]
EJ	JIC #4	2.44 [62.0]
JP	¼ Tube	2.60 [66.1]
JR	¾ Tube	2.73 [69.4]
JS	½ Tube	2.86 [72.7]
KA	¼ BSPT	2.42 [61.4]
RW	SAE ⅜-20	2.60 [66.1]

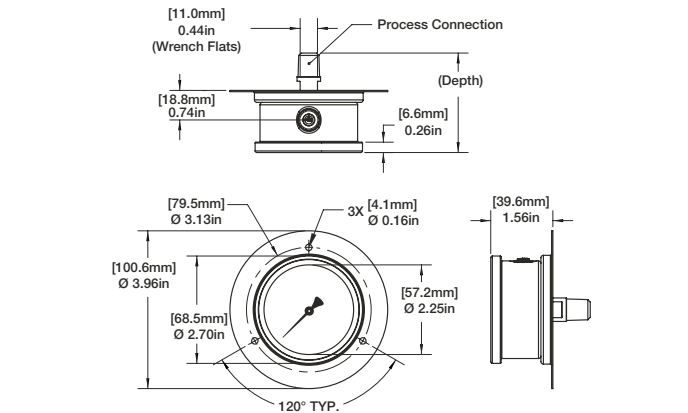

63 mm center back connect - protective boot

Connection Code	Process Connection	Depth
01	¼ NPT	2.36 [60.0]
02	¼ NPT	2.50 [63.4]
13	G¼ B	2.49 [63.3]
41	M14x1.5	2.53 [64.3]
EJ	JIC #4	2.44 [62.0]
JP	¼ Tube	2.60 [66.1]
JR	¾ Tube	2.73 [69.4]
JS	½ Tube	2.86 [72.7]
KA	¼ BSPT	2.42 [61.4]
RW	SAE ⅜-20	2.60 [66.1]

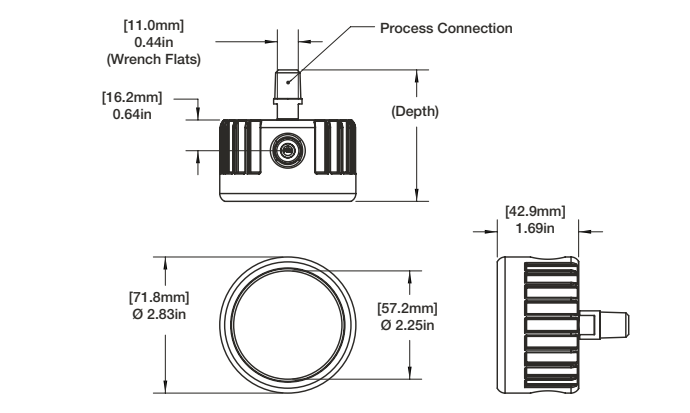

Contact Us

1.800.328.8258
ashcroft.com

All specifications are subject to change without notice. All sales subject to standard terms and conditions. Ashcroft®, FlutterGuard™ and Trust the Shield® are trademarks of Ashcroft Inc. For more information, see [Ashcroft Brands & Trademarks](#)
©2026 Ashcroft Inc. 8008S_ds_RevL_13-April-2026

8008S Pressure Gauge

Dimensions in [] are millimeters

For reference only, consult Ashcroft for specific dimensional drawings

63 mm lower back connect - XS3 option

Connection Code	Process Connection	Depth
01	¼ NPT	2.36 [60.0]
02	¼ NPT	2.50 [63.4]
13	G¼ B	2.49 [63.3]
41	M14x1.5	2.53 [64.3]
EJ	JIC #4	2.44 [62.0]
JP	¼ Tube	2.60 [66.1]
JR	⅜ Tube	2.73 [69.4]
JS	½ Tube	2.86 [72.7]
KA	¼ BSPT	2.42 [61.4]
RW	SAE ⅜-20	2.60 [66.1]

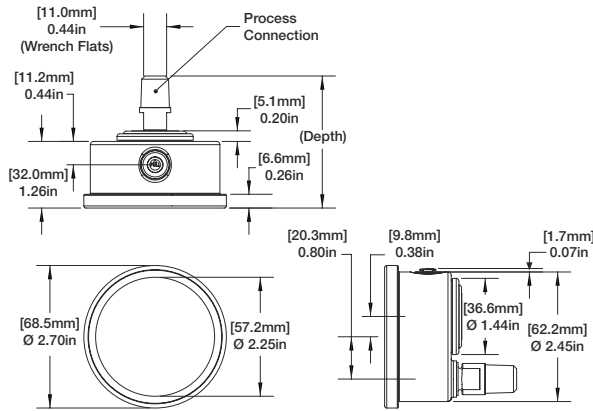

63 mm lower back connect, front flange - XS3 option

Connection Code	Process Connection	Depth
01	¼ NPT	2.36 [60.0]
02	¼ NPT	2.50 [63.4]
13	G¼ B	2.49 [63.3]
41	M14x1.5	2.53 [64.3]
EJ	JIC #4	2.44 [62.0]
JP	¼ Tube	2.60 [66.1]
JR	⅜ Tube	2.73 [69.4]
JS	½ Tube	2.86 [72.7]
KA	¼ BSPT	2.42 [61.4]
RW	SAE ⅜-20	2.60 [66.1]

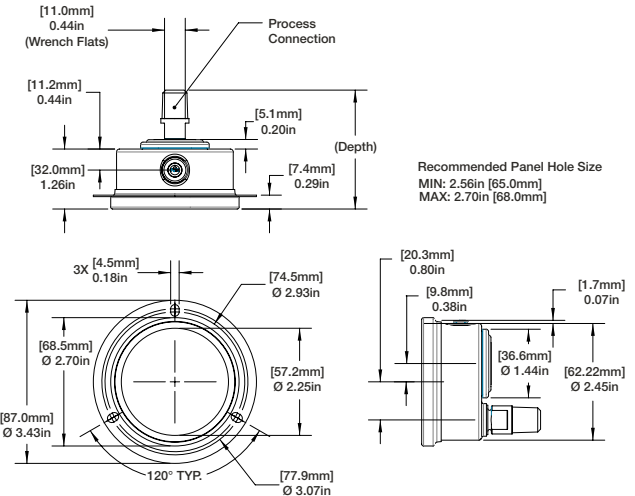

63 mm lower connection - XS3 option

Connection Code	Process Connection	Depth
01	¼ NPT	3.68 [93.5]
02	¼ NPT	3.81 [96.8]
13	G¼ B	3.81 [96.8]
41	M14x1.5	3.85 [97.8]
EJ	JIC #4	3.75 [95.3]
JP	¼ Tube	3.92 [99.6]
JR	⅜ Tube	4.05 [102.9]
JS	½ Tube	4.18 [106.21]
KA	¼ BSPT	3.73 [94.7]
RW	SAE ⅜-20	3.92 [99.6]

